

JULY 1976

# mini·micro systems

formerly MODERN DATA

## HAPPY BIRTHDAY AMERICA

DEC SYSTEM 20

LIBRARY INSTITUTE  
STATE TECHNICAL  
AT MEMPHIS

**Uninterruptible Power Systems**  
**Microprocessor Scorecard**  
**Small Business Computer Systems**

# Today!



**The Computer terminals you saw on the "Today" Show  
can be seen "live" in your office . . .**

**modular  
one**

**Now for  
End-Users!**

. . . Simply by calling one of the numbers below. This is the leadership line, from the Company recognized as the leading manufacturer of teletypewriter-compatible video display terminals. And now we're pleased to announce that, effective immediately, we're accepting orders from end-users for Modular One, the terminal that is fast becoming the new standard in its class.

Thinking "terminals"? Think Hazeltine, and call us today!



## **Hazeltine**

Corporation  
Computer Terminal Equipment  
Greenlawn, New York 11740  
(516) 549-8800

**A World Leader in Information Electronics for more than a half-century.**

East: N.Y. (212) 586-1970 □ Conn. (203) 875-6429 □ Boston (617) 429-4009 □ Phila. (215) 676-4348 □ Wash., D.C. (703) 979-5500 □ Rochester (716) 254-2479.  
Midwest: Chicago (312) 986-1414 □ Columbus (614) 864-4714 □ Detroit (313) 559-8223. South: Atlanta (404) 434-8444 □ Houston (713) 783-1760 □  
Orlando (305) 628-0132. West: San Mateo (S.F.) (415) 574-4800 □ L.A. (213) 553-1811 □ Denver (303) 770-6330 □ Seattle (206) 242-0505.  
Canada: MISCOE Data Communications Equipment Services, Ltd. □ Toronto (416) 678-7354 □ Montreal (514) 631-4381 □ Vancouver, B.C. (604) 731-0714.  
England: Hazeltine Ltd. 01-948-3111 Telex (851) 928572. Germany: Hazeltine GmbH 0611-590748 Telex (841)-416924.  
FOR WORLDWIDE SALES INFORMATION CALL: (516) 549-8800.

CIRCLE NO. 1 ON INQUIRY CARD

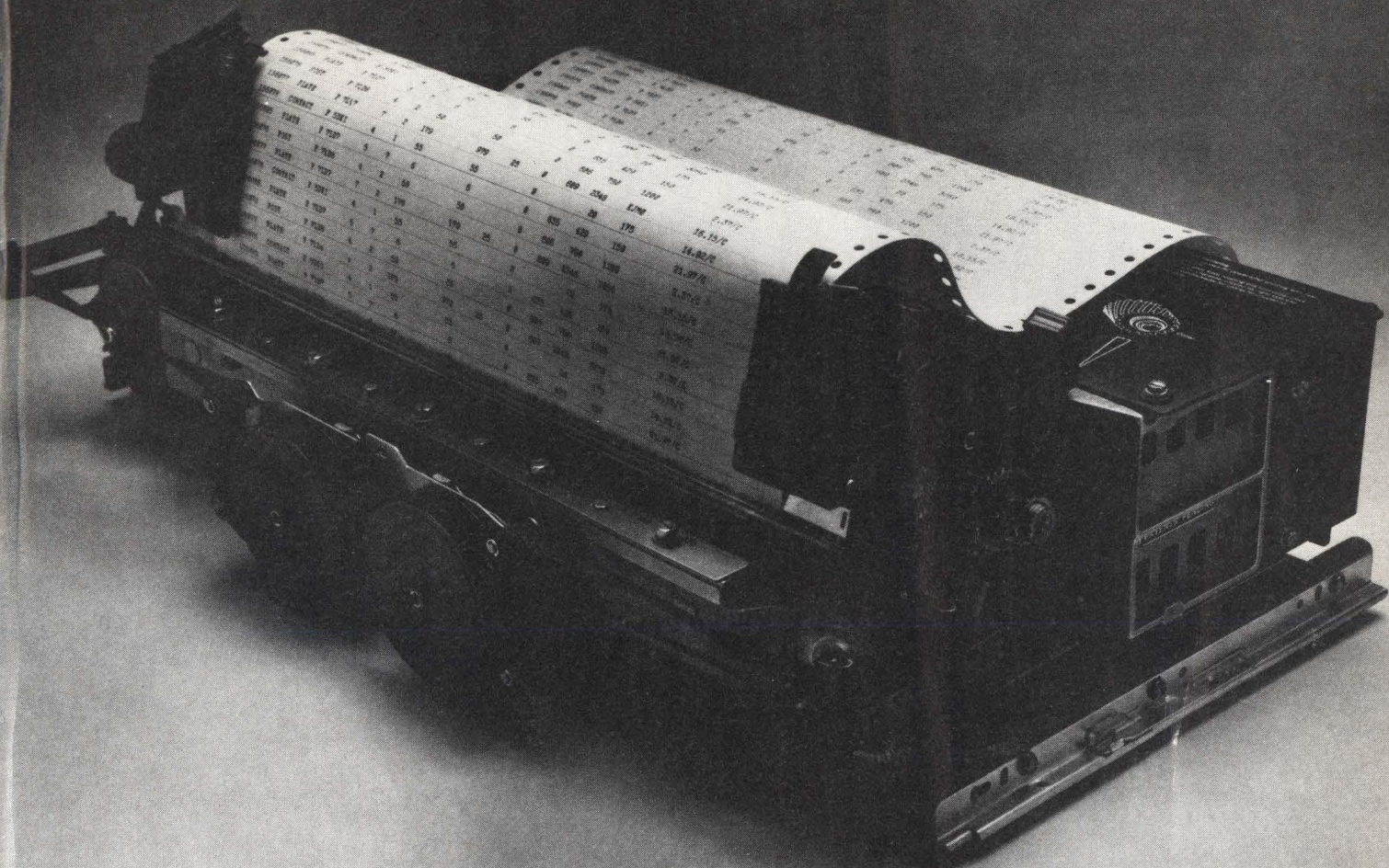

## **132 columns. Over 300 lines per minute. Under \$2000\*.**

In printers, it's not just a question of how much they cost, but one of how much you get for your money. And on a price/performance basis, nothing even comes close to the Teletype® model 40 OEM printer.

Besides getting a 132-column, heavy-duty impact printer that delivers over 300 lpm for less than \$2000, you also get a printer with outstanding flexibility and reliability.

The big reason behind the model 40's price/performance advantage over the competition is our unique design. Even though it operates at speeds over 300 lpm, wear and tear is less than you'd find in a conventional printer operating at a much slower speed. Fewer moving parts and solid-state components add up to increased reliability and reduced maintenance.

We'd be ahead if we just stopped there, but the model 40 also offers you a number of other features. Like a choice of character sets, operator-adjustable form width and form length, parity error indication, and a built-in self-test feature, just to name a few.

For complete information, please contact our Sales Headquarters at: 5555 Touhy Ave., Skokie, Ill. 60076. Or call Terminal Central at: (312) 982-2000.



**The Teletype model 40 OEM printer.  
Nothing even comes close.**

Teletype is a trademark and service mark registered in the United States Patent and Trademark Office.  
\*80-column-version available for under \$1400.

**CIRCLE NO. 2 ON INQUIRY CARD**

# You can depend on Exide<sup>®</sup> UPS.

## They do.



"Exide backs up its UPS reliability claims with a quick-response service department. MCAUTO has had three 200 KW UPS Units in operation since June, 1975 at its St. Louis data center. Eight more Exide 200 KW Units have been installed to provide full emergency power for 15 minutes. And two more are on order. We do depend on Exide UPS."

Theodore Kawula, Section Manager,  
McDonnell Douglas Corporation

"The foundation of our Foreign Currency Trading System for banks is reliable computer performance. To provide that performance we selected Exide for our computer power."

Philip D. Quarles,  
Vice President, Data Processing,  
TAFEX Systems Corporation



Exide UPS systems are protecting some of the largest computer centers in the country. An Exide Uninterruptible Power Supply system filters out the spikes and transients commonly found in raw utility power. And, depending on your time requirements, an Exide UPS system will

continue to feed smooth, constant power during utility blackouts and brownouts.

Major computer users who rely on Exide UPS systems are enthusiastic about their selection of this equipment. Quoted below are Exide customers whose comments are based on experience. There are many more, since Exide has been an UPS system supplier for more than a decade.

Exide is the only UPS manufacturer that makes all the major components: Rectifier/charger, stationary battery, static inverter and static switch. This means that your UPS will be carefully designed as a complete system. All the components, from the utility power takeoff to the computer interface, have a single source of responsibility—Exide. You can depend on Exide UPS.

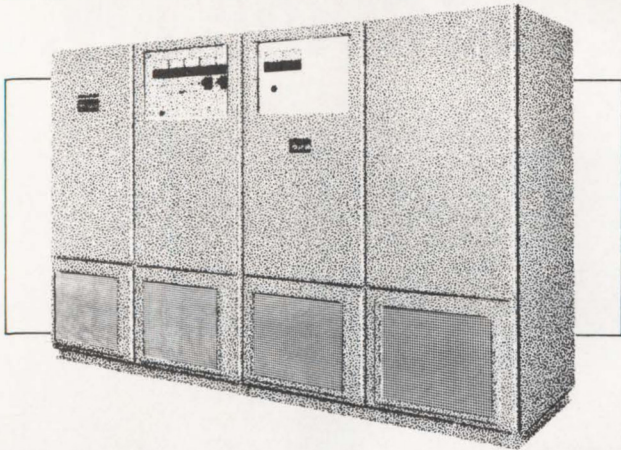

**ESB Exide**

EXIDE POWER SYSTEMS DIVISION,  
ESB INCORPORATED, Raleigh, N.C.

**CIRCLE NO. 33 ON INQUIRY CARD**

Exide is a registered trademark of ESB, Inc., Phila., Pa., for batteries and systems. Copyright © 1976. ESB, Inc. All rights reserved.

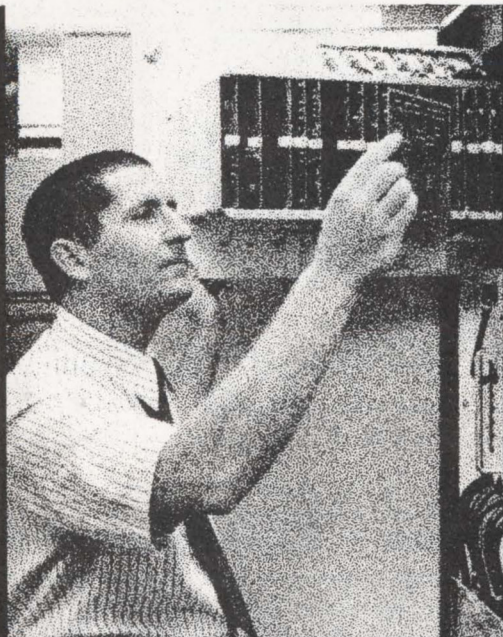

"We chose the Exide system primarily because of the ease of maintenance and repair. Due to its design, a person with basic electronic knowledge can troubleshoot and repair most failures. Also, we were impressed with the Exide representative's knowledge of their product and his knowledge of UPS Technology. Along with this, their equipment pricing was very competitive."

Robert Watters, Maintenance Engineer,  
Dallas Federal Savings

"When the energy crunch started in late 1973, COMPU-SERV realized that if we were going to continue to provide reliable computing services to our users, we would need to find a reliable, cost-effective 'uninterruptible power source.' After talking with several possible vendors, it became apparent to COMPU-SERV that Exide Power Systems could deliver such a system as a total package in a reasonable time frame. Our 250 KVA UPS has been on-line for over eighteen months now. We are pleased with the increased computing reliability this Exide UPS has allowed us to provide the remote users of our nine large systems."

Len Kaiser, Site Manager, COMPU-SERV



# The *Silent 700* ASR Data Terminal. It shares time with good company.



The twin-cassette *Silent 700*<sup>®</sup> Model 733 ASR data terminal from Texas Instruments is supported by every leading U.S. timesharing service company, a few of which are indicated here.

What's more, it's a powerful alternative to conventional teletype-writers. It's quiet. It transmits and prints data at 30 characters per second. And it reduces connect time and user cost.

Programs are prepared off-line and stored on cassettes, avoiding expensive connect time during data preparation. Result: More users can access the system without loss in response time. More computing time is delivered for the dollars spent.

<b>UCC</b> UNIVERSITY COMPUTING COMPANY	<b>MCAUTO</b> MCDONNELL DOUGLAS AUTOMATION COMPANY
 NATIONAL CSS, INC.	 UNITED <sup>®</sup> COMPUTING SYSTEMS, INC.
<b>COMSHARE</b>	Optimum Systems Incorporated
 On-Line Systems, Inc.	<b>CSC</b> COMPUTER SCIENCES CORPORATION
 computer time	 AETS COMPUTING CORPORATION
<b>chi</b> CORPORATION	 Computer Sharing Services, Inc.
	 CALL COMPUTER

User programs are stored on cassette locally, reducing the cost of disc file storage at the remote computer.

The Model 733 ASR lists for \$2895\*, including printer and twin cassettes. Attractive lease rates are available. And it is backed by worldwide TI service and support.

For more information, contact your nearest TI office. Or write Texas Instruments Incorporated, P.O. Box 1444, M/S 784, Houston, Texas 77001. Or call 713/494-5115, extension 2124.



**TEXAS INSTRUMENTS**  
INCORPORATED

\*U.S. Domestic Price

# TEXAS INSTRUMENTS.

CIRCLE NO. 3 ON INQUIRY CARD

Publisher, Editorial Dir. . . . . S. Henry Sacks  
Assoc. Publisher. . . . . William A. Gannon  
Editor-in-Chief . . . . . Stanley Klein  
Associate Editor. . . . . Barbara A. Reynolds  
Technical Editor . . . . . Dan M. Bowers

**CONSULTING & CONTRIBUTING EDITORS**

Boris Beizer	Alan R. Kaplan
Ralph Berglund	James I. Leabman
Maurits de Regt	Walter A. Levy
Ken Falor	Efrem Mallach
L.A. Feidelman	John A. Murphy
Ivan Flores	Malcolm L. Stiefel

**ART/PRODUCTION DIRECTOR**  
John W. Kelley, Jr.

**PRODUCTION ASSISTANT**  
Sally Haskins

**ADVERTISING PRODUCTION**  
Manager . . . . . Bernard Greenside

**ASS'T TO PUBLISHER**  
Pamela E. Page

**CIRCULATION DEPARTMENT**  
Carol Grace, Mgr.

All correspondence regarding circulation, advertising, and editorial should be addressed to the publication offices at:

**MINI-MICRO SYSTEMS**  
5 Kane Industrial Drive  
Hudson, MA 01749  
(617)562-9305

**SALES OFFICES**

Sales Mgr. . . . . Robert J. Bandini  
Mktg. Services Mgr. . . . . Melvin L. Hayden

**NEW ENGLAND**  
Melvin L. Hayden, 5 Kane Industrial Drive,  
Hudson, MA 01749 (617)562-9305

**NEW YORK**  
Irwin L. Werfel, E. Regional Sales Mgr.,  
Robert J. Bandini, 18 East 48th St., N.Y.,  
N.Y. 10017 (212)753-0375, (203)255-6293

**WEST COAST**  
David E. Pearson, 7135 W. Manchester Ave.  
Suite 3., Los Angeles, Cal. 90045 (213)  
670-5651

Published monthly and copyrighted 1976 by Modern Data Services, Inc., 5 Kane Industrial Drive, Hudson, MA 01749. The contents of this publication (in excess of 500 words) may not be reproduced in whole or in part without written permission.

**SUBSCRIPTIONS:** Circulated without charge by name and title to U.S.-based corporate and technical management, systems engineers, systems analysts, EDP managers, software specialists, and other personnel who qualify under our qualification procedures. Available to others at the rate of \$18.00 per year; single issues \$1.75. Subscription rate for all foreign subscriptions is \$25.00 per year (12 issues).  
**POSTMASTER:** Send Form 3579 to: Circulation Dept., Mini-Micro Systems, 5 Kane Industrial Drive, Hudson, MA 01749. Controlled Circulation postage paid at Long Prairie, MN.

Back issues of MINI-MICRO SYSTEMS (formerly Modern Data) are available on microfilm. Contact University Microfilms, 300 North Zeeb Rd., Ann Arbor, Michigan 48106 for ordering information.



JULY 1976 • VOLUME 9 • NUMBER 7

# mini-micro systems

formerly Modern Data

## 20 DATA COMMUNICATIONS

20 DATACOMM NEWS

## 26 PRODUCT UPDATE

UNINTERRUPTIBLE POWER SYSTEMS

26 Minicomputer System Power Requirements

30 Tracking Down and Identifying Power Line Aberrations

34 Efficiency – Key to UPS Selection

## 39 PRODUCT FOCUS

## 42 TECHNOLOGY PROFILE

Systems-On-A-Chip

Part 2 – Microprocessor Scorecard

A review of the extraordinary developments in semiconductor technology providing the impetus for the microcomputer revolution.

## 50 PRODUCT PROFILE

SMALL BUSINESS COMPUTERS

Buying Not Just Hardware, But Software

This Profile discusses the problems in choosing a standard configuration from among those systems offered by minicomputer manufacturers, so-called mainframe manufacturers, and minicomputer-based systems suppliers. A table listing major characteristics is included.

## COVER CREDIT:

To commemorate the bicentennial, we are featuring a biprocessor system with a "revolutionary" approach, appropriately decorated for the occasion. Unlike conventional dual-processor systems, a special interface permits a PDP-11 minicomputer to become an integral element of the total 36-bit Decsystem 20. More than the standard front end, the mini at times becomes the master processor of the system, particularly at initialization and during diagnosis. The revolution does not stop with features. Size is another aspect. Minis started it, now maxis are following. And like the American revolution it all began in Massachusetts. *Cover photo by Steve Grohe (Boston, MA)*

## DEPARTMENTS

- 6 NEWS & COMMENT
- 10 DC DATASCAN
- 14 INTERNATIONAL NEWS
- 19 CORPORATE & FINANCIAL
- 60 NEW PRODUCTS
- 62 NEW SOFTWARE & SERVICES
- 63 NEW LITERATURE
- 64 INDEX TO ADVERTISERS

READER INQUIRY CARD . . . . . OPPOSITE PAGE 64

## FAIRCHILD'S HOGAN — WE'VE COME A LONG WAY, BABY

By throwing the equivalent of \$18 million in 1951 computing power to the Electro '76 audience, Lester Hogan, vice-chairman of Fairchild, was able to show just how far we'd come. For each of the 18 F-8 chips that now costs \$3395 (Q = 100) is equivalent in processing power to IBM's original 701 that cost \$1 million in 1951. Hogan talked of the microprocessor revolution as part of an overall LSI revolution. Microprocessors are often too powerful to be economical, but LSI circuits are enough to replace many formerly electromechanical tasks. However, microprocessors will be responsible for a new business scene. Whereas large amounts of capital were required for computer products in the 60s, the low-priced microprocessor enables new companies to start with assets of only an idea. One example is the electronic game manufacturer. Within three years, companies such as Micro, Inc., have grown from sales of \$1.1 million to \$9.3 million. And this is only the beginning of that trend, according to Hogan. For it will be the electronic game connected to the television screen that will function as the first home computer terminal.

## RAYTHEON-INTERSIL SETTLE

Raytheon and Intersil have reached an out-of-court settlement in the \$2 million trade secrets lawsuit brought by Raytheon for theft of its bipolar memory technology. Raytheon's original complaint named Jean Hoerni, then Intersil chairman, and 13 ex-Raytheon employees who moved to Intersil in 1970. Intersil can use whatever it wants in return for a \$500,000 cash payment over the next four years and 120,000 shares of Intersil stock to Raytheon.

## WEMA PREDICTS

Worldwide semiconductor shipments will increase 24 percent over 1975 to \$4.98 billion, according to electronics industry trade association WEMA. This compares to the doldrum year of 1975, when shipments declined 17 percent. Among the major product groups included in the forecast, MOS devices are expected to jump 35 percent to \$1.1 billion; digital bipolar devices will rise 25 percent to \$841 million and linear devices will increase by 35 percent to \$583 million. The forecast is the composite of predictions by 49 U.S. semiconductor manufacturers. Copies of the forecast are available for \$2 from WEMA, 2600 El Camino Real, Palo Alto, CA 94306.

## FAVORITE DISK DRIVES

Users of IBM-compatible disk drives are generally happy with their performance and users of those produced by Memorex are happiest of all. That was the consensus of Datapro's survey of 199 users with 1811 IBM-compatible drives. The other six manufacturers line up like this: CalComp, Telex, Ampex, Control Data, Intel and Mohawk. Overall ratings ranged from 2.9 to 3.5 (4 = excellent). For copies of *All About Plug-Compatible Disk Drives*, write Datapro Research Corp., 1805 Underwood Blvd., Delran, NJ 08075. Price of the report is \$10.

## IBM REDUCES MOSFET MEMORY PRICES

Purchase prices for expanded MOSFET memory modules for the System/370 Models 115, 125, 158 and 168 and for the 3704 and 3705 II communication controllers have been reduced by IBM 7 to 35 percent. Also reduced were MOSFET memory prices in the small system range — System/3, System/32 and the 5100. These price reductions ranged from 10 to 35 percent. According to IBM, the price reductions are due to improved manufacturing techniques, but they will also slow down the intrusion of independents in the add-on memory market.

## COMPUTER SERVICE SEGREGATION

Adapso (Association of Data Processing Service Organizations) is worried about the spillover of the nonservice vendors into the computer services market. Its recent position paper, "The Incremental Marketing of Computer Services, Generally," is a supplement to one issued in 1972. The "spillover" occurs when an organization sells its unused computer time. Adapso fears that a leader of a nonservice market can use reciprocity and tying effects to force the computer service-only companies out of the market or to restrict entry into the market of new service companies. It wants to protect the computer service industry with a doctrine of separation, which would require banks, computer hardware and other nonservice firms selling services to have "separate facilities, separate personnel, separate name and whatever other separation is necessary to prevent the spillover of economic power from one separate line of commerce to another."

### WHAT'S COMING

- August 8-13** **Minicomputer and Microcomputer Institutes.** Pheasant Run Lodge, St. Charles, IL. Sponsored by National Engineering Consortium, Inc., 1301 W. 22nd St., Oak Brook, IL 60521.
- 23-27** **Microprogramming: Concepts, Design and Practice Course.** Georgia Institute of Technology, Atlanta, GA. Contact Director, Dept. of Continuing Education, Georgia Institute of Technology, Atlanta, GA 30332.
- Sept. 14-17** **Wescon/76.** Los Angeles Convention Center, Los Angeles, CA. Contact Wescon, 999 North Sepulveda Blvd., Suite 410, El Segundo, CA 90245.
- 20-22** **Data Entry Management and Supervision.** Cherry Hill Inn, Cherry Hill, NJ. Contact Management Information Corp., 140 Barclay Center, Cherry Hill, NJ 08034.
- 20-24** **Convention Infomatique (Data Processing: Today and Tomorrow).** Paris, France. Contact Convention Infomatique, 6 place de Valois, 75001 Paris.
- 22-24** **APL 76.** Ottawa, Ontario. Contact Comshare Ltd, 304-11 Adelaide St. West, Toronto, Ontario M5H 1m2.
- 23-25** **Microcomputer Interfacing Workshop.** Blacksburg, VA. Contact Dr. Norris Bell, Virginia Polytechnic Institute and State University Continuing Education Center, Blacksburg, VA 24061.
- 27-29** **Micro-9 (Ninth Annual Workshop on Microprogramming).** New Orleans, LA. Contact Micro-9 Computer Science Dept., University of Southwestern Louisiana, Box 4-4330, Lafayette, LA 70504.
- 28- Oct. 1** **Data-Kontor 76 (International Computer and Business Efficiency Exhibition).** Stockholm, Sweden. Contact Radley Communications Ltd., 509 Madison Ave., New York, NY 10022.



# A chip off the old block.

As you can see, this chip is housed in ceramic and mounted in a forty pin, dual in-line package.

As you can't see, it's a NOVA<sup>®</sup> computer.

Inside that packaging sits a full 16-bit, silicon gate, NMOS microNOVA CPU. The mN601.

The mN601 is the first microprocessor designed and manufactured by a minicomputer company. And it's the highest performance NMOS microprocessor on the market. With our 160 nanosecond RAM, it has a memory cycle time of 960 nanoseconds and the fastest instruction times going. Like an Add of 2.4 microseconds. And a Load of 2.9 microseconds.

The mN601 has the 16-bit NOVA instruction set including hardware stack for easy programming. And 16-bit data for efficient memory use.

It also has hardware multiply/divide for fast program execution. Integral data channel logic for easy interfacing to high performance peripherals. Control and timing for high density RAM memories. Integral hidden refresh logic that overlaps instruction execution timing. Plus a unique I/O encoding scheme for efficient easy interface design. Even the real-time clock is included. All of which reduces the chip count.

And all that computer is in a single chip.

And because the mN601 is a NOVA, it uses the most mature, field-proven software you can get with any micro. So you can cut back on development time and cost by using compatible software like our diskette-based Disc Operating System and our Real-Time Operating System.

Also, the mN601 comes with the full documentation support you'd expect from a minicomputer company like Data General.

If you want more than a chip, you can get it. There's a whole chip set, a 4K computer-on-a-board and a fully-packaged 9-slot microNOVA MOS mini. And there's more.

Don't stop here.

Sign up for a technical seminar on the microNOVA. They'll be held in major cities around the country from New York to Los Angeles. They'll last a half-day. And they're free.

For more information call our toll free number, 800-225-9497 (Unless you're in Massachusetts. In which case, call 1-617-485-9100 Ext. 2509.)

**microNOVA:**

A giant reduction in the NOVA line.

## DataGeneral

• Data General, Route 9, Southboro, Mass. 01772 (617) 485-9100. Data General (Canada) Ltd., Ontario. Data General Europe, 15 Rue Le Sueur, Paris 75116, France. Data General Australia, Melbourne (03) 82-1361

NOVA is a registered trademark of Data General Corp.

CIRCLE NO. 5 ON INQUIRY CARD

# Say When.

Introducing the Consul 520. Now you can get exactly what you need in teletypewriter compatible equipment. Without paying for what you don't need. Check the features below and say when.

Let's say you need:

- Inquiry-response capabilities.
- Remote controls to X-Y address or position the cursor up, down, forward, backward and home.
- Audible alarm and keyboard lockout.
- 12" screen; 24 lines with 80 character positions per line.
- Dark lettering on light background for increased legibility.
- Bonded faceplate TV monitor.
- Five transmission rates, switch selectable.
- Scrolled or wraparound display.
- Automatic line feed button.
- EIA RS232 or 20 milliamper current loop.
- Video output.
- Full-duplex or half-duplex transmission.

*It's the Consul 520. The meat-and-potatoes basic that's pure prime quality. It features as standard what most terminals call options. Single unit price, \$1595.*

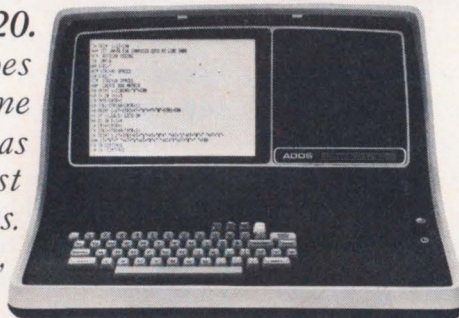

- Maybe you need all the above features, plus:
- Hard-copy capability with printer interface.
  - Cursor control keys.
  - Numeric pad.
  - Rack-mounting option.

*It's the Consul 580. Like all our terminals, the 580 has an extended warranty option, and OEM/Educational discounts. Single unit price, \$1795.*



Moving right along, we drop the printer interface, and give you the above, plus:

- Protected formats.
- Block transmission to cut down on CPU functions and considerably reduce software needs.
- Selective transmission of only variable data.
- Upper and lower case ASCII display.
- Shift and lock keys.
- Transmission by page, partial page, line or character.
- Look-ahead cursor positioning to suppress trailing blanks.
- Automatic tabbing between fields.
- Half-intensity.
- Blinking at two rates.
- Remote recognition of cursor position.

*It's the Consul 920.  
With its sophistication  
and flexibility, the 920  
is a network designer's  
dream. Without a  
nightmare price.  
Single unit price,  
\$2600.*



Still with us? Then you need the works:

- Graphics that show everything from bar charts to diagrams.
- Alphanumeric annotation of graphics.
- Line insert or delete; remote or local.
- Character insert or delete.
- Overwriting.
- Parallel and serial peripheral interfaces.
- Remote or local printing.

*It's the Consul 980.  
Top of the line,  
and acts like it.  
You simply can't  
buy better.  
Single unit price,  
\$2800.*



Now. If you've said when, we'll say where:  
Applied Digital Data Systems Inc., 100 Marcus Blvd.,  
Hauppauge, New York 11787 (516) 231-5400

# ADDS

CIRCLE NO. 39 ON INQUIRY CARD

Now you can rent ADDS terminals through the General Electric  
Instrumentation and Communication Equipment Service.



## GSA'S BIG MINI BUY

Not all of the heat in Washington is generated on the Hill. GSA has just released an RFP for a maximum of 25 minicomputer systems which is billed as a requirements contract — not a mandatory requirements contract. This RFP has been in the works for almost three years and represents a GSA attempt to make a volume buy of a complex product which will result in a contract which is available to all agencies. GSA has encountered considerable opposition among vendors and trade groups. However, one group of firms — the systems houses — welcome the procurement at least until all but one of them loses. The procurement represents the culmination of a long pull for GSA to implement the Brooks Law and GSA has been under considerable pressure from Congress and GAO to make this buy.

### Controversy

The controversy boils up in several areas. Some vendors feel the specification does not represent the real needs of any agency but is rather a conglomeration of needs which will result in a shopping catalog. The theory goes that every agency will either need more or less machine and thus the buy will fit the actual needs of very few.

## Variety of Peripherals

Essentially this RFP offers a firm a chance to break into the government market in a big way. However, the wide variety of peripherals requested mitigates against any firm other than a systems house from winning. Such a firm can buy in OEM discount quantities and put together a system. Such a system runs a very big risk of being a dead-end product with no downstream enhancements and hence may not be very attractive to the sophisticated user. This seems to be what has happened in previous quantity buys.

This RFP also requires level pricing for delivery anywhere in 48 states. Most firms don't even have offices in all 48 states. The RFP places a major burden on the bidder with regard to maintenance in those remote sites. And the government has no idea how many machines will be installed in each state let alone where in each state. The vendor is supposed to gaze into the crystal ball and come up with a price for such unknowns. If he builds too much margin because of the unknowns he will lose. If he builds too little he will win and lose his shirt. This is further complicated by the fact that the guaranteed quantity is only 25 systems while the government reserves the right to order 225 additional systems at its discretion.

One way to deal with this problem is to charge list price for the first 25 and begin to discount beyond that point. Then the government only realizes the prices of the lowest offeror when the 250th system is ordered. This places problems on the government. Everyone will want to order the cheaper systems later.

GSA has reacted to a two year period of vendor pressure by making this contract a requirements contract rather than a mandatory requirements contract. This has little net effect within the regulations. The only possible difference will be the degree of selling GSA does for the winner among user agencies and the fact that GSA may not fight agencies so hard which do not wish to use the contract. Otherwise, if the government continues to buy from other sources after this award the government may be guilty of breach of contract.

### Time to Act

Potential bidders had better jump on GSA and find out what, exactly, they are bidding for, which agencies will use it for what projects, what excuses to avoid use of the contract will be acceptable to GSA, and which ones will be acceptable to the winning vendor. This RFP involves a lot of hardware and dollars. Proposals are due on August 19 and the contracting officer is Victor Primeau who can be reached at 202/566-0771. Every potential supplier should get into the act for or against.

## Compare our 32-port MUX to Data General's:

OURS	THEIRS
DMA channel operation (one interrupt per transmission)	I/O channel operation (one interrupt per character)
Easily handles 32 terminals at 9600 baud each	Bogs down with three terminals at 9600 baud
Baud rates under program control	Baud rates hard wired
Two printed circuit boards	Eight printed circuit boards (4060's)
Modem control and real-time clock included	Two more boards needed for modem control
Approximate price: \$6,400	Approximate price: \$13,000
Warranty: One year	Warranty: 60-90 days

Clearly, seven solid reasons for choosing Educational Data Systems' Nova-type multiplexer. It's simpler, smaller, costs about half and is warranted longer. It's available in 4, 8, 16 and 24 port modules and supports both synchronous and asynchronous communication. Remarkably, it interfaces up to 128 peripheral devices and virtually eliminates costly central processor overhead.

## Then write for more information.

NAME \_\_\_\_\_  
 CO./INSTITUTION \_\_\_\_\_  
 TITLE \_\_\_\_\_ PHONE \_\_\_\_\_  
 ADDRESS \_\_\_\_\_  
 CITY \_\_\_\_\_ STATE \_\_\_\_\_ ZIP \_\_\_\_\_



### Educational Data Systems

17981 Sky Park Circle, Irvine, CA 92707 Phone: (714) 556-4242  
\*Nova is a Reg. Trademark of Data General Corp.

## EASING EXPORT CONTROLS

Amid mounting pressure from Congress, the Commerce Dept. and the Coordinating Committee (CoCom) have decided to ease export control guidelines for computer products sold to the Eastern Bloc. The pressure from Congress is in the form of a bill recently approved by the Senate Banking and Currency Committee, which would set export limits on a country-by-country basis. In the meantime, CoCom has set up threshold levels for various approvals.

The lowest threshold, needing only Commerce Dept. approval, is a CPU Processing data rate under 13 megabits per second and internal memory below 4.72 megabits. The second threshold, which needs and is likely to get Pentagon approval, is a CPU processing data rate less than 32 megabits per second and internal memory less than 6.3 megabits. Beyond that, the same approval cycle applies.

The proposed bill would consider each country (East and West) individually — what relationship it has to the U.S., its relationship to U.S. adversaries and its willingness to re-export U.S. technology.

# Our 3270 replacement: Judge it by the companies who keep it.



It was price that first caught the eye of most Computer Optics customers. A price that's as much as 50% below IBM's 3270 monthly charge. But leading companies want more than a bargain. They want value. The kind of value our CO:77 information display system delivers.

Value in performance through reduced operator fatigue with a faster refresh rate and faster remote data rates. Value in features with a larger display area, movable screen that tips to the operator's best viewing angle and touch sensitive keyboard. And value in service, with responsive service to all installations.

If you're planning a central or remote display installation, or expanding an existing facility, call Computer Optics.

You'll be in good company.



**Computer Optics Inc.**

Berkshire Industrial Park, Bethel, CT 06801

Call toll free: 800-243-1314 In Connecticut call collect (203) 744-6720

CIRCLE NO. 9 ON INQUIRY CARD

### NETWORK CENTRAL

- Satellite Program Preparation
- Satellite Program Storage
- Satellite Program Test-Execution
- Satellite System Generation
- Satellite System Download
- Satellite Program Scheduling
- Forced Satellite Program Load
- RJE to IBM
- Central Initiated Communication
- Use of Satellite Peripherals

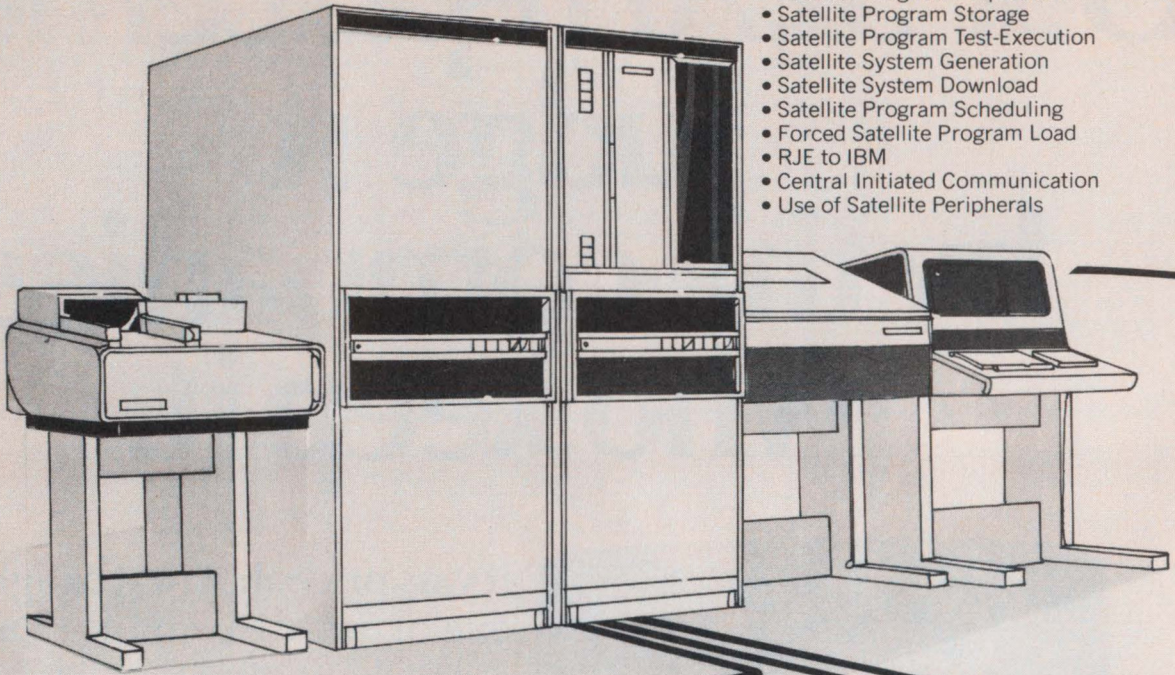

### MEASUREMENT AND CONTROL SATELLITE

- Satellite Initiated Communications
- Central Program Scheduling
- Synchronous or Asynchronous Data Transfer
- Automatic Retransmission on Parity Errors
- 1,000 Kbps at 600' Hardwired

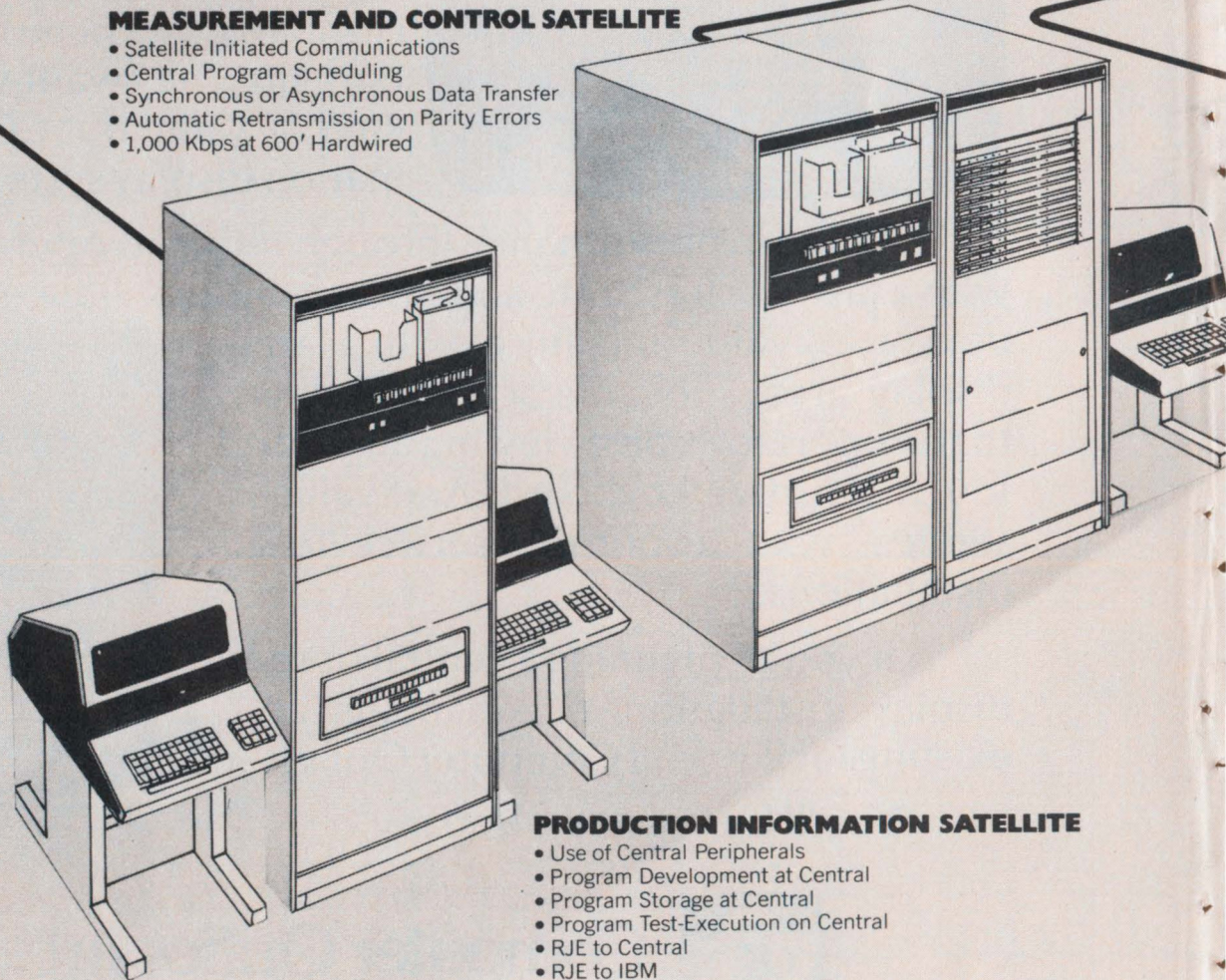

### PRODUCTION INFORMATION SATELLITE

- Use of Central Peripherals
- Program Development at Central
- Program Storage at Central
- Program Test-Execution on Central
- RJE to Central
- RJE to IBM

# THERE'S BEEN A LOT OF TALK ABOUT COMPUTER NETWORKS.

## HEWLETT-PACKARD'S SPEAKS FOR ITSELF.

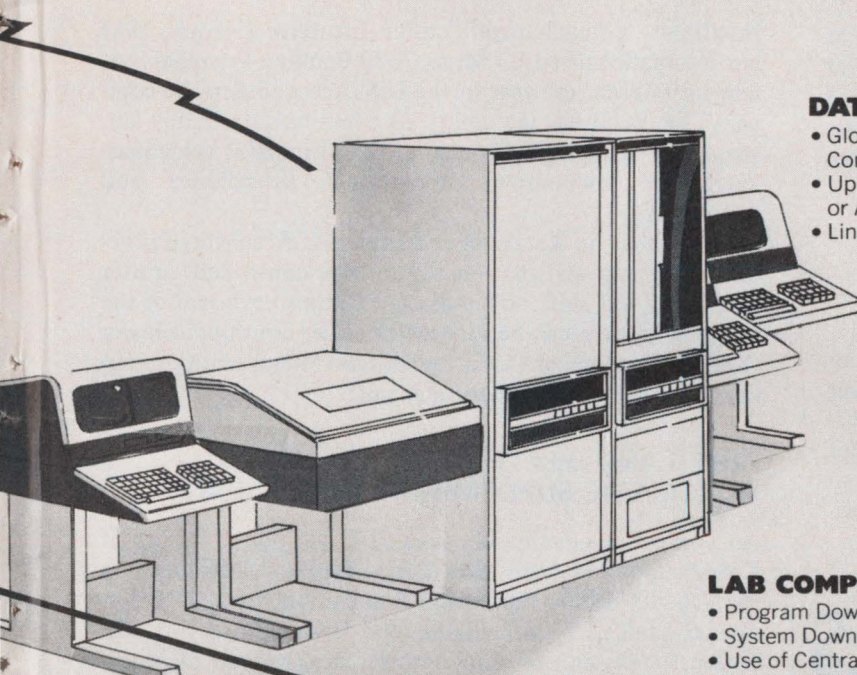

### DATA ENTRY SATELLITE

- Global Program to Program Communication
- Up to 19.2 Kbps via Synchronous or Asynchronous Modems
- Line Diagnostics for Line Status

### LAB COMPUTATION SATELLITE

- Program Download
- System Download from Central
- Use of Central Peripherals
- Program Development at Central
- Forced Satellite Program Load
- Hardwired to 10,000'
- Remote File Access

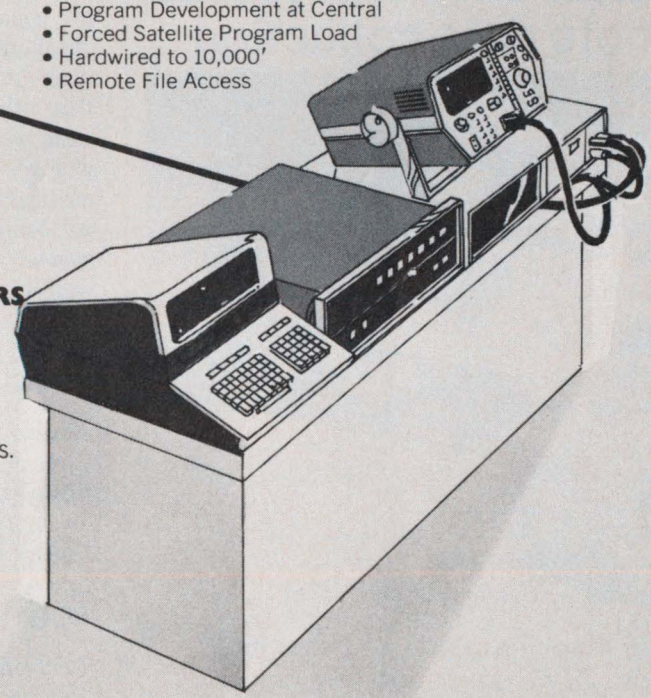

### HP COMPUTER NETWORKS ARE NOW WORKING FOR MORE THAN 100 CUSTOMERS

Customers have been using Hewlett-Packard networks since 1973. And, as the illustration shows, for a lot of good reasons. HP has what you need — the hardware *and* the all-important software — to make full use of a 21MX minicomputer network tailored to your applications. Make us prove it. Write or call today.



Sales and Service from 172 offices in 65 countries.  
1507 Page Mill Road, Palo Alto, California 94304

For assistance call: Washington (301) 948-6370, Chicago (312) 677-0400, Atlanta (404) 434-4000, Los Angeles (213) 877-1282, Toronto (416) 678-9430

CIRCLE NO. 4 ON INQUIRY CARD

22617

## NOT EVEN IBM CAN IGNORE JAPANESE

In a rare admission of concern, IBM Chairman Frank Cary told shareholders at the annual meeting that Japan can't be overlooked. Although Japan is a latecomer in the data processing industry, it is almost equal to IBM in hardware, five years behind in software and five to ten years behind in components. And with heavy government subsidies for only two competitive combines (NEC/Toshiba and Fujitsu/Hitachi/Mitsubishi), it won't take the Japanese long to catch up or leap forward as they did in the automobile industry. Fujitsu affiliate, Amdahl, is already giving IBM problems in the U.S. And in Japan, Fujitsu is giving IBM problems with the M series in the 370 market. NEC/Toshiba is also entering the 370 market as well as the small business market. One-half of the computer market in Japan belonged to IBM in 1960; today it's one-third.

## DATAWEST MONITORS NATIONALIST CHINESE

The Nationalist Chinese are using Datawest's computer monitoring system for their nuclear reactor being constructed on Taiwan. This is in preparation for full nuclear power utilization by the mid 1980s. Datawest's data acquisition equipment measures the temperature of the nuclear fuel rods and provides continuous temperature readings to the computer. In the event of an impending thermal runaway, the system will shut down the reactor.

## PORTABLE KEY PUNCHES for remote data collection

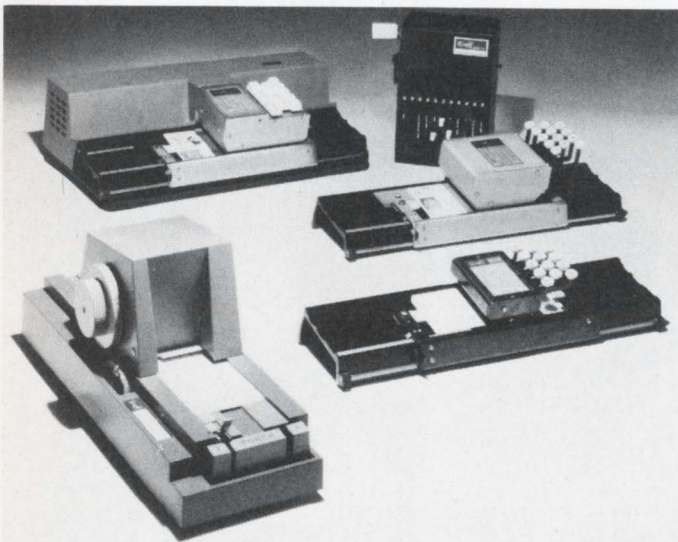

For punching machine readable holes in 80 column cards, 22 column cards, 51 column cards, card sets, credit cards and plastic I.D. badges. Standard manual and electric models or special configurations in OEM quantities. Send today for brochure giving details.

*Wright*  
LINE

WRIGHT LINE INC. 160 Gold Star Blvd., Worcester, Mass. 01606

CIRCLE NO. 8 ON INQUIRY CARD

## NIPPON ENTERS SYSTEM/32 MARKET

Nippon Electric Co. (NEC) is making its bid for the small business market first in Japan, later in the U.S., with the Neac 100E and 100F systems. Both use custom 16-bit microprocessors and 4K MOS memory chips. Main memory size ranges from 16 to 32 kilobytes and prices range from \$24,600 to \$68,833.

## KATAKANA SPOKEN HERE

Intelligent terminal manufacturer Incoterm (Natick, MA) has internationalized its Series 7000 Banking Terminal System introduced last year in the U.S. According to the company, the 7000 has the ability to communicate in any language — even Japanese Katakana. The terminal is being marketed by Incoterm's international subsidiaries and distributors.

Also fluent in Katakana is Sycor's 440K clustered processing system and its microprocessor-controlled printer series. The left shift of the display station keyboard of the clustered system can be locked for either continuous lower (Katakana) or upper (Latin) positions. Mitsui and Co. market Sycor's line of products in Japan.

## BIRTH AND DEATH OF AUTOMATIC SUPERMARKETS IN JAPAN

An unmanned supermarket opened in the Tokyo suburb of Kokubunji last May and closed one year later. Developed by the Japan Machine Promotion Association, the OK Supermarket handled 2500 kinds of food from canned goods to frozen foods, with 67 vending machines. Instead of inserting coins in the machine, customers inserted a plate. The checkout terminal then computed the total amount on the plate. Although the store claimed 7 percent lower prices than other stores — due to lower labor cost — average daily sales were less than one-fifth of those projected. Japan, which is ahead of the U.S. in POS and EFTS systems, is having trouble convincing consumers that this is the way to go. Among consumer complaints were that they could not squeeze, pinch or shake the goods, that they would rather wait in a checkout line than punch vending machine buttons, and that machine buying takes the fun out of shopping.

## CDC DATA SERVICES GLOBAL EXPANSION

Always with an eye on the international side of things, Control Data Corp. is going to expand its data services organization to Brussels, Canada and the Far East. CALL/37, an interactive time sharing service, will be available in both Europe and the Far East.

## FOOTHOLDS ABROAD

Tealtronix Nederlands B.V. has become the European manufacturing licensee and distributor for the Printronix 300 line printer/plotter. Tealtronix also markets and manufactures the Flexowriter and Shugart disk drives in Europe.

Interscan Data Systems, Ltd., a marketing organization of England, will market, service, and develop applications for Ontel programmable CRTs in the U.K., Germany and the Eastern Bloc countries.

# DP Dialogue

Notes and observations from IBM that may prove of interest to data processing professionals.

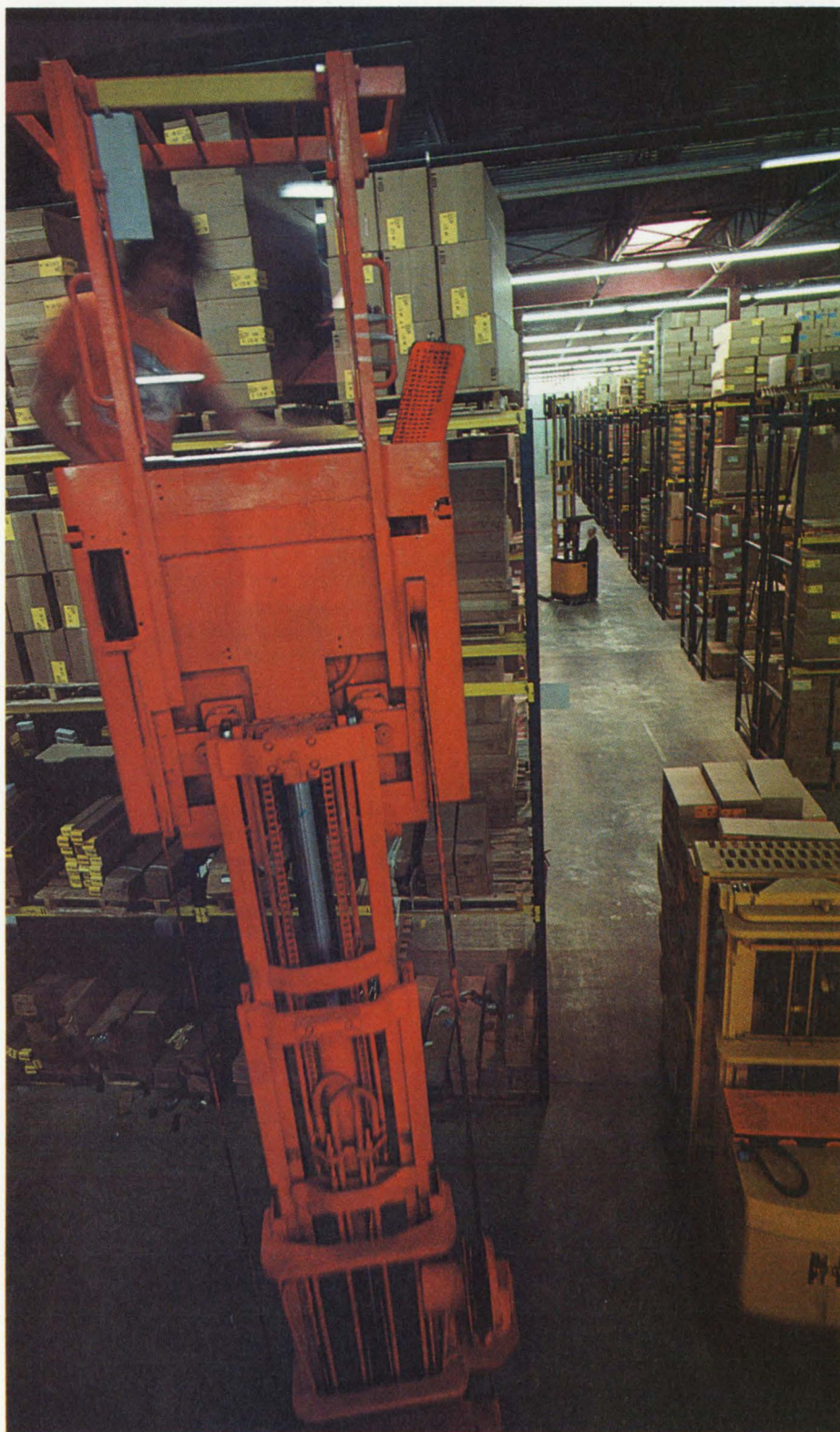

*Distributed processing has stepped up the efficiency of warehouse operations at Wilson Sporting Goods Co.*

## Distributed Processing Links 25 Wilson Field Locations

Few companies today operate entirely out of one location. Even small firms are likely to have regional sales offices, while larger businesses may have dozens of operating units scattered across the country. For such organizations, a distributed processing system may help bring about some notable operating efficiencies.

Wilson Sporting Goods Co. of Chicago, a division of PepsiCo, is an outstanding example. Wilson is both a manufacturer and distributor of sporting goods, with one of the broadest lines in the industry. The company recently realigned its distribution network and now has 21 sales offices, each of which stocks some inventory, plus 4 large regional distribution centers. An IBM 3790 Communication System links all 25 locations to a System/370 Model 158 computer.

In a distributed processing system like the 3790, the workload is shared between the central computer and smaller units called controllers, which act as small processors. In the Wilson network each location has a controller online to a cluster of terminals and a printer, creating 25 small computing centers with local data processing capability.

Typically, after an order is entered at a Wilson sales office, it is transmitted via the 3790 to the Model 158 which forwards it to the appropriate regional center or centers. As the order is being processed, Wilson's companywide data base—including open orders, shipped orders and inventory—is updated. Customer inquiries concerning order status can be answered quickly through any terminal in the network.

"Customer service has benefitted greatly with the 3790," says Phillip D. Matthews, vice president, distribution.

*(Continued on next page)*

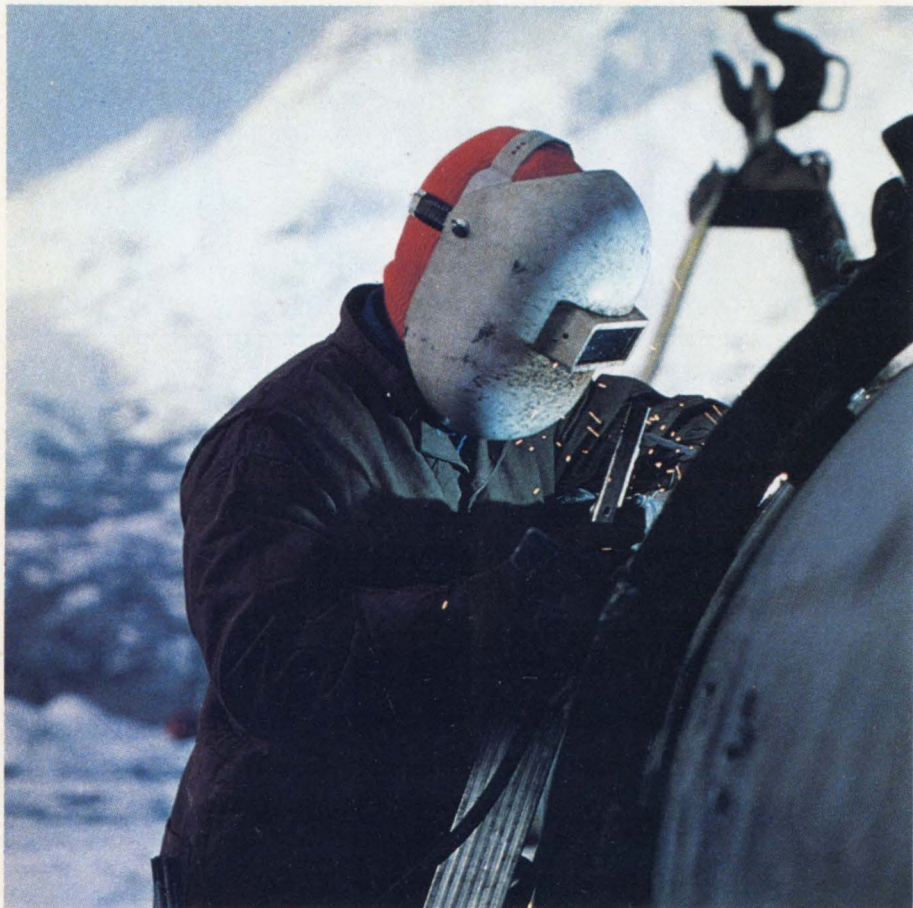

A pipe casing is welded on the Alaska pipeline. To help manage the \$7 billion project, the Alyeska Pipeline Service Company is using an IBM System/370 Model 145.

## Alyeska Develops a Total DP System in Record Time

When the Alyeska Pipeline Service Company was formed in 1970 to supervise the design and construction of the Alaska pipeline, many of the details of the project were still a big question mark. The only absolute certainty was the immensity of the challenge, particularly in the area of management control. The job called for the development of a total data processing system which would be flexible enough to handle very rapid growth.

Every aspect of the planning, construction and administration of the 800-mile pipeline must be fully documented to meet Federal environmental and regulatory requirements. That includes keeping track of inventory consisting of everything from Arctic outer gear to spare parts, managing a work force which swells to over 20,000 during the summer and providing accounting information for thousands of separate parts.

From the beginning, Alyeska has relied on various IBM computers to help handle the information. As the

project progressed, the quantity of accounting data mushroomed quickly. "We went from processing less than 100 invoices a day out of our temporary offices in Seattle in 1974 to handling between 2-to-3,000 invoices daily on our Model 145 with VS/1 today," says Art Potter, manager of systems and computing. "Our online data base now

### Wilson...

*(Continued from preceding page)*

"The time required to process and ship orders has been cut almost in half. All our sales offices now get order and inventory reports overnight, instead of two or three weeks later. And nine out of ten items ordered are filled on demand, without backordering. Overall, office and warehouse productivity rose 30%.

"The system has made possible much closer coordination between manufacturing and sales," he adds.

includes over 2,500,000 records and it's still growing."

The toughest part of planning the system, according to Potter, was anticipating future data processing requirements without specific guidelines. "It was like compressing a 10-year corporate history into two years," says Potter, "We had to get every application up within a few months, because the actual pipeline construction was moving ahead so quickly."

Alyeska's system includes data processing equipment at five major construction sites and the Model 145 in Anchorage. Overall, the system must keep track of all the bills submitted to Alyeska by nearly 10,000 subcontractors. Each week, a performance report on pipeline progress is sent to the eight oil companies that own Alyeska for review on costs and efficiency.

Ultimately, records of all the expenses associated with the pipeline will go to the Interstate Commerce Commission (ICC) which is responsible for determining the rate of return the oil companies will be permitted to earn on their investment. Every expense will have to be documented and justified for the ICC.

When the pipeline is finally completed, Alyeska will be responsible for the total operation of the pipeline and terminal facilities at Valdez, Alaska. Currently, new data processing applications are being developed to support these pipeline activities. For example, sensing devices along the pipeline will transmit information to a computer in Valdez, which in turn will communicate with the System/370.

"One thing is certain," says Potter, "we could never have coordinated a project of this size without the computer. The financial accounting alone would have been a nightmare. We are confident that the experience our staff has gained working under the Alaskan constraints will provide us with the ability to develop the applications required when the oil starts to flow."

"Since we are constantly up to date on order volume, we can adjust production in advance to meet demand.

"All these factors, plus our new physical distribution facilities, have culminated in a reduction of approximately \$10 million in our total inventories—which in turn has increased cash flow and reduced our need for working capital."

The 3790 runs under Systems Network Architecture (SNA), an advanced IBM teleprocessing structure that unifies communications networks for greater efficiency and easier growth.

# Bell Helicopter Gets a Lift from Computer-Aided Design

A helicopter rotor spins at 300 revolutions a minute as its turbine engine runs at 6,000 RPM. A multistage transmission, designed and manufactured by Bell Helicopter Textron, accomplishes a twentyfold reduction to provide lift for the craft. That capability alone makes it a very complex mechanism, but at Bell there is an additional requirement: the transmission must be able to run dry of oil for thirty minutes and survive.

That level of performance requires very precise design parameters. Bell's engineers have been using the Fort Worth company's IBM System/370 Model 168 to help produce reliable, cost-efficient helicopters. Much of the designing is done by engineers who interact directly with the computer via twenty-five IBM 3277 and 2741 terminals which are linked to the Model 168 under the Time Sharing Option (TSO) and OS/V5-SVS.

"With interactive computing, we've been able to increase the productivity of many engineers by a factor of four,"

says Joe Red, chief of scientific and technical computing. "By evaluating more options in the same time, they can minimize technical risks."

At Bell, computer-aided design is used to model everything from human factors, like legroom and headroom, to helicopter "survivability" under the most turbulent conditions. The company has developed over 500 specific application programs which run the gamut from designing the smallest gears to simulating the flight characteristics of the entire aircraft.

The computer is also used to formulate the "egg shell" configurations—the geometry of an aircraft's skin. In the manufacturing area, the computer keeps track of manpower requirements, operations plans and parts production schedules.

"Interactive computing and a comprehensive data base," says Red, "have helped us design and produce rotorcraft with the classical aerospace virtues—maximum strength, minimum weight and as much payload as possible."



*Computer applications in plant design are growing fast at UOP. This engineering model is of a new process plant.*

## Multiprocessing Ups Availability at UOP

"With our corporate computing load increasing by 37% a year for the last several years, system availability had become critical." So says Steve Bloch, director of corporate computer services for UOP Inc., explaining the company's recent move to an IBM multiprocessing (MP) system.

UOP, (formerly called Universal Oil Products Company) headquartered in Des Plaines, Illinois, is an engineering-oriented company which designs and builds petrochemical process and pollution control systems, and manufactures their engineered components. A major subsidiary constructs refineries. Its System/370 Model 158MP serves users in 18 divisions in the U.S. and Europe, plus several non-UOP companies.

In the multiprocessing system, two "tightly coupled" central processors back each other up to insure system availability. A single control program under the Multiple Virtual Storages (MVS) operating system automatically allocates work between the processors, dynamically assigning the load for maximum work throughput and best utilization of all resources.

"Certain of our applications—such as shop order control—are synchronized with physical operations," Bloch explains, "so computer availability is vital. That's why we wanted the backup facilities and automatic error recovery of the multiprocessing system."

In a three-shift, six-day-a-week operation, Bloch notes, the system has been available more than 99.5% of the time.

Engineering productivity is also crucially dependent on computer avail-

*(Continued on next page)*



*The final touches are being applied to a helicopter at Bell Helicopter Textron in Fort Worth. The aircraft was designed with the help of computer simulations.*



The USAA home office is one of the world's largest and most efficient office buildings.

## In Texas, a Giant Data Base Produces King-size Results

What insurance company has insured every military man who has walked on the moon? What's the largest property and casualty insurance company headquartered in Texas? Who is San Antonio's biggest private employer?

The answer to all three questions is the United Services Automobile Association. USAA is a unique member-owned cooperative, with over a million policyholders. Most members are active or retired commissioned officers in the armed forces and their dependents—

and they're stationed all over the world. USAA has no agents. Its policyholders communicate with it mostly by mail and telephone.

To help meet their insurance needs — automobile, home, life, property — with efficiency and dispatch, USAA relies on a comprehensive IBM computing system built around an immense data base. It's one of the largest data bases running under IBM's IMS (Information Management System) used by any property and liability insurer any-

where, with 4.8 billion characters of online storage. The system runs on an IBM System/370 Model 168 computer.

The data base is remarkable for more than size. Unlike the insurance industry practice of indexing by policy numbers, USAA indexes by account (policyholder) numbers. Account numbers are cross referenced to policyholder's names. An average of three active policy numbers are carried under each account number.

This innovative policy of "a name, not a policy number" has some unusual advantages. A complete profile of any member's policies and other data can be flashed on any of 275 visual display terminals, both at the San Antonio home office and at five regional service offices around the country. Much of this data can be updated online, with the rest processed overnight.

And the transactions are copious. They include a daily average of 36,000 automobile data entry transactions, 24,000 policyholder online updates, 80,000 general inquiries, plus 5,000 hard copy batch document requests.

Data entry procedures, both for written forms and terminal display, are sequenced so that what appears on the terminal screen parallels the information on source documents. Compared with previous methods, this new online data entry system has reduced required keying time by 30% and operator training time by 60%. The transactions are edited as they are entered, thereby reducing the number of errors coming into batch processing by over 30%.

"Probably the best way to measure the cost effectiveness of our data processing operation is to compare the USAA underwriting expense ratio with the rest of the insurance industry," says Col. Martin Fishel, senior vice president, computer services. "Each year, USAA reports one of the lowest expense ratios in the industry. Our computer systems are a major factor in keeping these expenses down."

### Multiprocessing...

(Continued from preceding page)

ability, he adds. Most of this work is unscheduled: engineers simply enter linear programs or other large-scale calculating jobs at will, via remote terminals in 22 locations.

This variability of demand was an important factor in the choice of a multiprocessing system. The UOP system solves difficult scheduling problems in sufficient time to avoid conflicts, eliminating most manual scheduling.

Engineers at Des Plaines use IBM's Time Sharing Option (TSO), which permits them to interact directly with

the computer, completing their solutions while seated at visual display terminals. TSO also enables engineers to validate input data before initiating computer runs—preventing costly reruns and shortening turnaround time.

The data processing department itself uses TSO to enter and test programs under development. In this application, Bloch asserts, TSO has increased programmer productivity by 62%.

Bloch says, "the multiprocessing system has been remarkably flexible, absorbing wide fluctuations in volume. It's given us excellent availability while responding well to our increasing demand for interactive computing."

*DP Dialogue appears regularly in these pages. As its name suggests, we hope DP Dialogue will be a two-way medium for DP professionals. We'd like to hear from you. Just write: Editor, DP Dialogue, IBM Data Processing Division, White Plains, N.Y. 10604.*

76-4

**IBM**®

Data Processing Division

## CIPHER NOW UNPERTECTED

Pertec Corp. has entered into an agreement for the sale of Cipher Data Products, San Diego, to an investment group led by Bill Otterson, current President of Cipher. Terms of the agreement call for the purchase price to be substantially in cash with the balance by note along with the assumption of all obligations of Pertec in conjunction with Cipher. These obligations include a guarantee of \$800,000 to Wells Fargo Bank that was assumed by Pertec at the time of the acquisition of Computer Machinery Corporation. No other terms of the agreement were disclosed.

## DIGITRONICS COAST-TO-COAST

Data 100 Corp. has sold the assets of its paper tape, "Portaverter" and magnetic tape cartridge product lines to a newly formed Rhode Island company, Comtec Information Systems. Comtec has also acquired the trade name "Digitronics." (Remember them?) Terms of the sale involving a combination of cash and notes were not disclosed. Heading the new corporation is Alfred J. Petteruti, former Data 100 vice president and chairman of Odec, Inc., which Data 100 acquired in November 1974.

## COMPUTER OPTICS COMPLETES LEASE FINANCING

Computer Optics, Inc. of Bethel, CT, has signed a lease financing agreement with North American Corporation. According to the company, the agreement provides for North American to purchase up to \$5,000,000 worth of Computer Optics' CO:77 Display Terminal Systems. The agreement is for a 3-year period, and provides warrants to purchase up to 500,000 shares of Computer Optics' Common Stock, provided the full amount of the \$5,000,000 of equipment is purchased by North American Corporation.

## SDC AWARDED \$5.4 MILLION CONTRACT

System Development Corp. has been awarded a \$5.4 million contract by the National Oceanic and Atmospheric Administration (NOAA). The 34-month project calls for SDC to develop the Data Processing and Services Subsystem for the National Environmental Satellite Services's TIROS-N Ground System.

## ON THE MOVE

Prime Computer, Inc. has announced its plans to add a 70,000 square foot addition to its present Framingham, MA, corporate headquarters. The addition will more than double the present

building space which houses engineering, manufacturing, marketing and corporate staffing . . . . .  
**Peripheral Dynamics, Inc.** will relocate its manufacturing and marketing operation to a new facility. The new plant is located at 1850 Gravers Rd., Plymouth

Township, Norristown, PA. PDI is presently located in the East Norriton Industrial Park, Norristown, PA . . . . .  
**Microcomputer Systems Corp.** has moved to a new 12,000 sq. ft. facility in the Oakmead Industrial Park, Sunnyvale, CA.

## EARNINGS (LOSSES)

**Digital Equipment Corp.** reported third quarter operating revenues of \$191,234,000 as compared with \$134,642,000 in the third quarter of fiscal 1975, up 42 percent. Service and other revenues accounted for \$39,321,000 of the total, 41 percent ahead of the \$27,946,000 reported a year ago. Net income totaled \$18,922,000 or \$1.53 per share. A year ago the company reported earnings of \$11,329,000 or \$.95 per share. For the nine months ending March 27, 1976, the company reported total operating revenues of \$504,293,000 versus \$373,232,000 a year ago.

**California Computer Products, Inc. (CalComp)** reported that an earnings turn-around in the second quarter of fiscal 1976 was continued in the third quarter, ended March 28, 1976. Pretax earnings were \$640,000 on revenues of \$30,667,000 compared to a pretax loss of \$6,307,000 on revenues of \$26,210,000 for the third quarter a year ago. For the nine months' period ended March 28, 1976, a pretax loss of \$2,313,000 was recorded on revenues of \$88,817,000 compared with a pretax loss of \$4,555,000 on revenues of \$90,956,000 reported a year ago.

**Data General's** sales for the 12-week period ended March 13, 1976 were \$34,089,000, up 38 percent over sales of \$24,639,000 for the second period of the previous fiscal year. Earnings after taxes for the second period were \$4,018,000, or \$.42 per share. This compares with earnings after taxes of \$2,866,000, or \$.35 per share for the comparable period last year.

**Digital Computer Controls, Inc.** announced that sales, net income and new orders received, all increased to new highs for the fiscal year ended February 29, 1976. "Earnings rose to \$625,262 or \$.40 per common share from \$230,697 or \$.15 per share last year," chairman Harold Rapaport reported. Sales improved steadily through the year, he said, reaching \$11,388,812, compared with the year-earlier total of \$9,756,140.

**Fairchild Camera and Instrument Corp.** reported first quarter earnings of \$197,000, or \$.04 per share, compared with year-earlier earnings of \$3,255,000, or \$.62 per share, before the cumulative effect of an accounting change. Total sales for the quarter rose to \$94,624,000 from volume of \$69,757,000 the year before.

**Hewlett-Packard Co.** reported sales for the second quarter ended April 30 totaled \$279,764,000, compared with \$248,357,000 for the corresponding quarter of fiscal 1975. Net earnings amounted to \$23,771,000, equal to \$.86 per share on 27,821,990 shares of common stock outstanding. This compares with earnings of \$23,952,000, equal to \$.87 a share on 27,492,522 shares, during last year's second quarter.

**Modular Computer Systems, Inc. (MODCOMP)** reported sales and income for the quarter ended March 31 were \$9,811,000 and \$280,000 or \$.10 per share, assuming full dilution, as compared with \$8,672,000 and \$548,000 or \$.19 per share, assuming full dilution.

**Motorola, Inc.** reported sales and other revenues for the first quarter were \$347.0 million, up 14 percent from the \$303.9 million a year ago, a record high. Earnings in the quarter were \$16.9 million, or \$.60 per share, an increase of 122 percent from the \$7.6 million, or \$.27 per share, for the first quarter of 1975.

**Prime Computer, Inc.** reported sales for the first quarter ended April 4, 1976, of \$3,957,000, an increase of 78 percent over sales of \$2,226,000 for the corresponding period last year. Net income for this quarter, after utilization of tax loss carry forward, was \$365,000 or \$.16 per share compared to \$52,000 or \$.03 for the same quarter last year.

**Wang Labs, Inc.** announced consolidated revenues for the three months ended March 31, 1976 amounted to \$22,947,000, an increase of 32 percent over the comparable period a year ago. Net earnings increased to \$1,102,000 in 1976 from \$170,000 in 1975.

**REPORTS AND PUBLICATIONS**

Could IBM become a public utility? It's possible, according to a study published by **The Yankee Group** of Cambridge, MA. Entitled *The Unbundling of AT&T: Implications and Opportunities*, the 160-page study considers the effects of the current U.S. Justice Department antitrust suit against the giant carrier. In a critical chapter, a former key man on the FCC's AT&T Task Force describes the merging of communications and computing and thus the "crossover" between AT&T and IBM." At \$500, the study can be ordered from The Yankee Group, PO Box 43, Harvard Square, Cambridge, MA 02138 . . . Shipments of communicating word processors (CWPs) will more than quadruple in two years as many new vendors enter this market, according to *Communicating Word Processors*, a 230-page report available from **International Resource Development Inc.**, 46 Main St., New Canaan, CT 06840 . . . While CWP's are multiplying by four in two years, the number of programmable terminal printers will be on its way to a *six-fold* increase, as predicted by the **International Data**

**Corp.** in its report entitled *Terminal Printer Market*. From 1974 to 1980, said highly respected IDC, standalone and clustered programmable terminals will increase from 47,300 to 303,300. During the same period, the aggregate of all kinds of terminal printers will double. For more information, write to **International Data Corporation**, 214 Third Ave., Waltham, MA 02154 . . . The latest opus from the prolific **Center for Communications Management, Inc.** (PO Box 324, Ramsey, NJ 07446) is *The Intrastate Guide to Communication Services (Volume 1)*, which goes for \$375. CCMi reminds us that state- and local-tariffed equipment and services, which are not as visible as interstate, FCC-tariffed offerings, typically account for *two-thirds* of the corporate communications budget . . . A newsletter that will interest many readers of this section is *Trends in Communications Regulation*, a new monthly that interprets "the importance of telephone regulatory events to business telephone users." Published by **Economics and Technology, Inc. (ETI)**, the newsletter is available for \$80 per year from 101 Tremont St., Boston, MA

02108 . . . Teleprinter users rate the products of **Computer Transceiver Systems** and **Digital Equipment Corp.** about equal in overall performance and substantially higher than the terminals produced by the six other leading suppliers of this type of equipment. That's one of the key findings in *All About Teleprinter Terminals*, a 42-page report published by **Datapro Research Corp.** and available for \$10 per copy. For more information, write **Datapro**, 1805 Underwood Blvd., Delran, NJ 08075 . . . And here's a dictionary to round out the lot. Published by **Van Nostrand Reinhold** (New York, NY), the *Data Communications Dictionary* (\$19.95) is reportedly "the first dictionary to cover [data processing and communications] in one convenient volume." The 14,500-term dictionary encompasses such state-of-the-art subjects as electronic funds transfer systems, microprocessors, and satellite and packet-switched transmission.

**AT&T BILLS DRAW FIRE**

Opposition to the Consumer Communications Reform Act of 1976 is growing more widespread and more vehement. In a recent letter to Members of Congress, the **Independent Data Communications Manufacturers Association** stated that "the purported benefits" of the growing number of bills now being filed under the title of the Consumer Communications Reform Act are "unfounded and unsubstantial," and further that "the effects of these bills would be adverse to the public interest." The Senate bill and the various House bills also incited five specialized carriers to band together as the **Ad Hoc Committee For Competitive Telecommunications**. Consisting of **MCI Communications Corp.**, **Data Transmission Co. (DATRAN)**, **Graphnet Systems Inc.**, **Southern Pacific Communications Co. (SPCC)**, and **United States Transmission Systems, Inc. (USTS)**, the Committee attacked AT&T and the U.S. **Independent Telephone Association (USITA)** as the presumed primary lobbyists for the bills. The strongly-worded statement criticized "AT&T and its allies" for "seeking to turn back the clock" just as "the public is beginning to receive the benefits" of five years of competition in the business, data and record services sectors of the communications market.

The Committee apparently felt bolstered by recent statements by FCC Chairman **Richard E. Wiley**. In a statement before the **International Communications Association**, Wiley opined that the objective of the

# MAG TAPE SYSTEMS FOR MINICOMPUTERS

Compatible with PDP-11, PDP-8, NOVA, and HP 2100.

Reliability backed by a full one-year warranty.

Prices from \$4,750 for a complete system which includes transport, controller cables and diagnostics.



## DIGI-DATA CORPORATION

Supplier of magnetic tape transports and systems.

8580 Dorsey Run Road, Jessup, Md. 20794 (301) 498-0200

831 S. Douglas St., El Segundo CA 90245 (213) 640-2060

Fluestrasse 632, 5313 Klingnau, Switzerland TELEX: 845-58555

CIRCLE NO. 10 ON INQUIRY CARD

lobbying efforts "is to sweep away every last vestige of this Commission-made and, to date, court-upheld policy" of allowing competition in limited sectors of the market. While praising the dedication and achievements of the Bell System, Wiley strongly attacked AT&T's major recent arguments against, in the words of AT&T Board Chairman John D. deButts, "rigged competition." The FCC chief indicated, for example, that the combined revenues of specialized carriers do not exceed \$170 million, compared with the telephone industries' \$4 billion in competitive market sectors.

In noting that AT&T could not demonstrate that interconnection had caused "any deterioration of the nationwide switched network," in spite of a decade of attempts, Wiley ridiculed AT&T's recent "not surprising" switch to economic arguments against interconnection. Although the telephone industry has not yet presented any convincing predictions of "economic harm," Wiley said, the FCC nevertheless can always consider numerous alternatives to preventing competition if the telephone industry *did* prove its point. Two of these alternatives, Wiley said, are the imposition of access charges for terminals interconnected with the telephone network, and the collection of separations payments from specialized carriers who use local loops.

#### AUTOMATIC DIALER

Xerox Corp.'s new automatic dialer accessory, to be used with the Xerox Telecopier 200 transceiver, can be preset to dial other copiers and transmit



copies (unattended) at reduced late-evening telephone rates. Announced in 1975, the Xerox 200 sends and receives letter-size documents by telephone at the rate of two minutes per page, less for smaller sizes. The automatic dialer system will be available fourth quarter, 1976. Price is \$3500.

#### GRI 99 ONLINE

GRI Computer Corp. (Newton, MA), manufacturer of System 99 small business systems, has announced an add-on package to permit communications between the System 99 and other systems. Called the Model 9610, the new package is designed for attended or unattended service, and is priced at \$5210 for software, hardware, modem, and cabling. The Model 9610 features a

Communications Control Language (CCL) for the user's development of disk-stored communications directives or interactively-provided directives. According to the manufacturer, the CCL can provide for remote or distributed processing as well as the shipment of data base updates between systems. The GRI System 99 is a multi-user, real-time, business system utilizing the GRI 99/50 minicomputer and supporting interactive RPG II.

**Sci-en-tif-ic:** eminently learned or skillful

**Busi'-ness:** any of the various operations or details of trade or industry

**Sys'-tems:** orderly combinations or arrangements of parts, elements, etc., into a whole

# SCIENTIFIC BUSINESS SYSTEMS INC.

**Our name tells a lot about what we do. For you.**

Many small and medium sized businesses are discovering they can both lower their costs, and raise their revenues by using our scientifically designed computer systems. We are specialists at developing high compliance turnkey computer programs for business applications.

Hardware, software, training, trouble shooting, maintenance—we take care of *all* your computer requirements. So you can take care of business. For full information on how our turnkey computer program can help you increase your business revenues, write or call today.

Scientific Business Systems, Inc.  
801 N. Easton Rd., Willow Grove, PA 19090  
(215) 657-3045





**A FASHIONABLE TELEPRINTER.**  
Vardon & Associates (Irving, TX) will make your teleprinter beautiful and quiet.

**HYCOM-MILGO AGREEMENT**

Hycom Inc. (Irvine, CA) has granted Milgo Electronic Corp. (Miami, FL) and its subsidiary International Communications Corp. exclusive rights to use Hycom's modem patents and technology in the general end-user and OEM markets. Hycom also announced it has terminated its modem sales representatives. Hycom explained that it initiated its adaptive modem program in 1972, expecting that capture of new business offered by the advent of sub-one-minute fax would give it the leverage to penetrate the general modem market. When sub-one-minute fax was delayed, Hycom saw in Milgo an even better channel to the general market. The modem technology sold to Milgo includes a fully programmable, high-speed N-channel LSI signal processor. Through a change in ROM coding, the user can meet the various modulation patterns, carrier frequencies and operating modes required by CCITT and Bell standards. Under the agreement, Milgo also licensed Hycom to use certain of Milgo's datacomm patents.

**TERMINALS**

*Incoterm* (Natick, MA) has two new series of intelligent terminals — Series 30 and Series 40. The Series 40 Intelligent Terminal System includes cartridge disk storage operated under *Incoterm's* Program Development and File Management System (PD/FMS) and offers 32K, 48K or 64K bytes of core memory. Maximum display cluster sizes are 16 1920-character or 32 960-character CRT keystations. The basic 10-megabyte cartridge disk is expandable in 10 MB increments to 40 MB. Other software includes an assembler, data entry software, Basic, an IBM 3270 emulation program and optional diskette-based operating system. The Series 40 also supports IDLC — *Incoterm's* subset of IBM's SDLC. The Series 30 features 16K, 32K, 48K or 64K bytes of programmable memory, 16 1920-character or 32 960-character CRT keystations, floppy disk storage and DOS software.

Circle No. 230 on Inquiry Card

Another micro-based terminal is the *Applied Systems Corp.* (St. Clair Shores, MI) Portable Intelligent Terminal. This is a *neon-plasma* display terminal that handles 8x32 characters. Usable at speeds up to 9600 bps. The 64-character ASCII terminal fits into a 18x12-inch carrying case.

Circle No. 233 on Inquiry Card

A product of Israel, the *Eltaterm 8504* is a microprocessor-based CRT from *Elta Electronics, Ltd.* The terminal has a standard typewriter keyboard and 7x9.5-inch display.

Circle No. 235 on Inquiry Card

The Model COM communication matrix printer from *Hydra Corp.* (Mountain View, CA) is said to be the first commercially available printer that can print continuously short lines at 1200 baud without requiring transmission of pad characters for carriage return and line feed. Hydra developed a microcomputer controller for this printer to allow the entire buffer memory to be used, regardless of line length. Speed of the printer ranges from over 800 lines per minute for lines with less than five characters to 150 lines per minute for 136-character lines.

Circle No. 231 on Inquiry Card

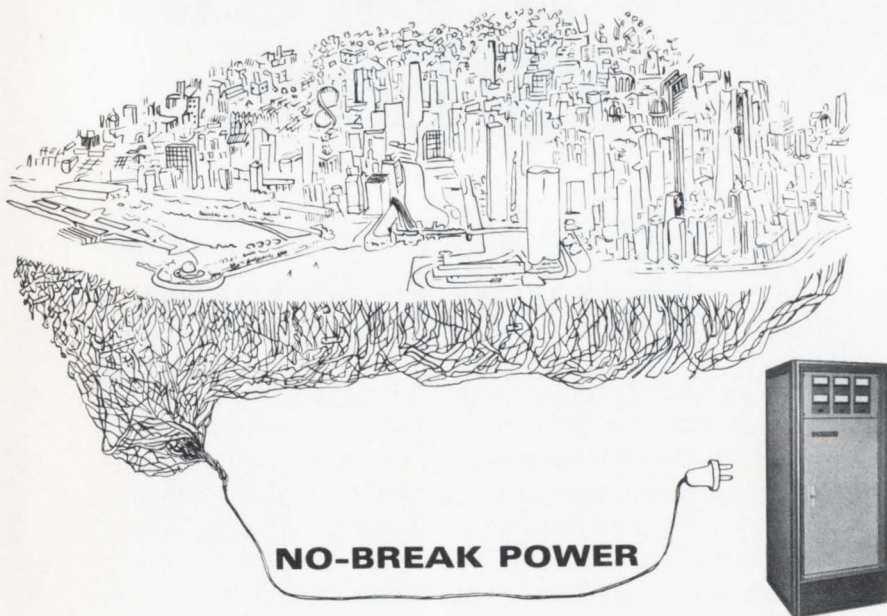

A silent watchman protects the city's computer terminals. An *Electro-Pac* UPS (Uninterruptible Power System) smoothes out voltage peaks, dips, and spikes. It continues to supply all the power your computer needs when the electric utility can't. From a microsecond to hours this silent watchman furnishes clear, clean uninterruptible power. . . . All's well!

For further information, prices, and leasing terms contact:



**ELECTRO-PAC**

129 Laura Addison, Illinois 60101  
AC 312 543-6200 TWX 910-991-5945

CIRCLE NO. 12 ON INQUIRY CARD

*Sidereal Corp.* (Portland, OR) and *Lane Telecommunications, Inc.* (Houston, TX) have introduced a microprocessor-controlled ASR teleprinter called *Micro Net*. Features include autodial, automatic time/date stamp on all messages sent and received, and a mini buffer mode allowing the user to create a short message in the buffer memory and send it automatically without using tape. The terminal also has a built-in self-diagnostic capability that allows the operator to isolate problems in the terminal, in the microprocessor module or online.

Circle No. 232 on Inquiry Card

The 8025C Communications Display Terminal from *Omron Corp. of America* (Mountain View, CA) is a firmware programmed, microprocessor controlled CRT designed for standalone or online data entry. The 1920-character display uses a 7x9 dot matrix with half-dot shift.



Scrolling and editing features are also included. Refresh memory stores up to 48 lines (two pages). Transmission rates to 2400 baud, asynchronous, are supported. Price in OEM quantities is \$3000.

Circle No. 234 on Inquiry Card

*RCA Service Co.* (Camden, NJ) now offers a Model 33 ASR teleprinter. Equipped with a 101C data set, the 33 ASR is compatible with Bell System Data Phone service and Western Union TWX service. RCA will also furnish Models 35 and 38 with 101 data sets.

Circle No. 236 on Inquiry Card

*Carterfone* (Dallas, TX) has added the Lear Siegler ADM-3 display terminal to its market offering. Available in 12 and 24-line versions, the ADM-3 operates at speeds to 19,200 baud. Options include upper- and lowercase and numeric pad. Price for the 24-line version is \$1145.

Circle No. 237 on Inquiry Card

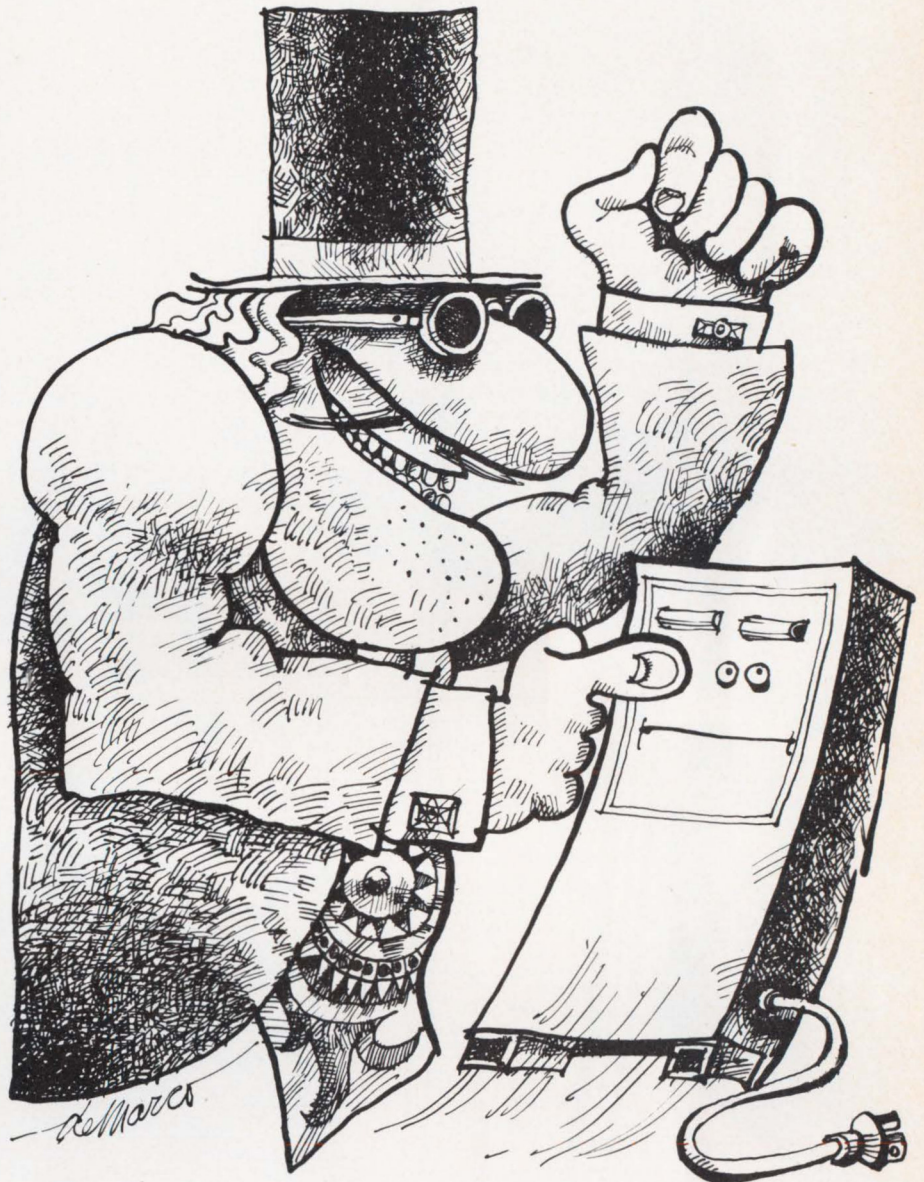

## Buy protection. Or else.

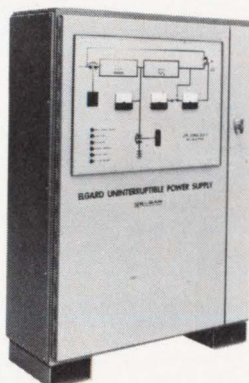

Or else when the power fails, your computer can lose its mind, its memory... and your data. But an Elgard Uninterruptible Power System can give your computer all the protection it needs—up to several hours of back-up time, plus continuous isolation from line spikes and transients. Elgard models are available in 0.5KVA through 40KVA capacities.

You'd better buy protection. Get in touch with us for complete information. Before your computer is rubbed out. Elgard Corporation,

**ELGAR**  
Elgard also is a leading producer of AC Line Conditioners and AC Power Sources.

8225 Mercury Ct.,  
San Diego,  
California 92111,  
Phone (714)  
565-1155.

CIRCLE NO. 13 ON INQUIRY CARD



# Announcing the biggest breakthrough ever in core storage.

MEMORY+. It's an entirely new dimension in bulk memory for minicomputers. An add-on memory system used with MODCOMP computers to give you a whopping 4,000,000 bytes of directly accessible core storage. At far less cost than any other core memory you could ever buy. Until now.

It opens up vast new possibilities for storing those programs and data you can't accommodate in main memory, but frequently need to get at—super fast.

Because now you have the best of two worlds. The capacity of disc. With the high speed and reliability of main memory. At an amazingly economical price.

The big breakthrough came when we found a way to slash the cost-per-bit of core by condensing a massive 256K bytes of memory into a single memory plane. In a single MEMORY+ device, anywhere from one to sixteen of these memory modules go together for a total capacity of 4 megabytes.

Consider what MEMORY+ can mean to you.

**Think of it** as a giant extension to main memory. It's both word and block addressable, and it swaps data so fast it appears to be a part of main memory itself.

**Think of it** as a way to beat the sluggish speed of fixed head disc. With its core memory access time, and transfer rates as high as five megabytes per second.

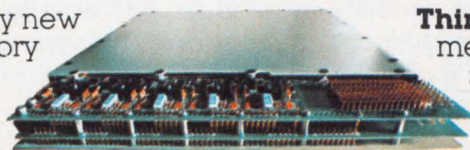

The MODCOMP 256K-byte memory module that made it all possible.

**Think of it** as a shared memory in multi-processor systems. Two MODCOMP computers can be processing the same data at memory speeds, without tying up main memory.

**Think of it** as an operating system auxiliary memory. Boosting system throughput by providing fast access to often-used operating system files.

**Think of it** as a direct data path to main memory for external data, used as a high-speed buffer.

Any way you look at it, MEMORY+ is one giant step forward in real-time bulk storage.

And because of its modular design, you buy only the capacity you need now. As you need more, add more plug-in modules.

It's simple. It works. And it's available. Now.

Call your nearest MODCOMP sales office for full details. Or write for a comprehensive 20-page brochure that explains the whole MEMORY+ story.

Modular Computer Systems, 1650 West McNab Road, Ft. Lauderdale, FL 33309. Phone (305) 974-1380. European Headquarters: Export House, Woking, Surrey, England. Phone (04862) 71471.

## MODCOMP MEMORY+

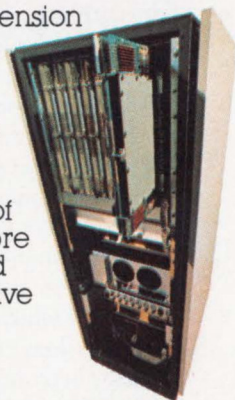

Four MEMORY+ devices give this MODCOMP computer an external core storage capacity of 16 megabytes, operating at main memory speeds.

MODCOMP SALES OFFICES: ALBUQUERQUE, NM/ATLANTA, GA/BOSTON, MA/CHICAGO, IL/CINCINNATI, OH/DALLAS, TX/DENVER, CO/DETROIT, MI/HOUSTON, TX/HUNTSVILLE, AL/INDIANAPOLIS, IN/KANSAS CITY, KS/LOS ANGELES, CA/MONTREAL, CN/NEW YORK, NY/ORLANDO, FL/PHILADELPHIA, PA/PITTSBURGH, PA/ROCHESTER, NY/SAN JOSE, CA/SEATTLE, WA/WASHINGTON, DC/INTERNATIONAL OFFICES OR REPRESENTATIVES IN ENGLAND/France/BENELUX/WEST GERMANY/NORWAY/SWEDEN/JAPAN

CIRCLE NO. 14 ON INQUIRY CARD

# UNINTERRUPTIBLE POWER SYSTEMS

## EDITOR'S NOTE:

Since 1972, this publication has annually devoted its July issue to the subject of uninterruptible power systems, line isolators, regulators and monitors. This year we continue this coverage with articles on UPS selection, noise, grounding and power line monitoring and isolation.

## minicomputer system power requirements

R.M. TEETS and D.L. JOHNSON / Deltec Corp., San Diego, CA

### THE "CLEAN LINE"

The first-time purchaser of a minicomputer-based computer system is told that the system requires no special power: it plugs into the wall just like an electric typewriter. Sometime before the contract is signed, the salesman points out that power should be supplied from a "clean line." When questioned, he explains that this simply means that one circuit breaker in the power distribution panel is to be used for the minicomputer system, and nothing else.

The experienced design engineer planning to incorporate a minicomputer into his data processing system allocates a large part of his budget to considerations of signal grounding and proper power distribution. He also plans to make sure that his system is powered from a "clean line." This "clean line" is often the same power distribution system that supplies nearby arc welders, elevators, electric typewriters, and other sources of electrical noise. The "clean line" also introduces a set of power problems from the outside world. It is, therefore, more than a little "dirty."

Providing the isolated circuit breaker is only one important step in connecting the minicomputer to the utility power lines, and greatly reduces the probability of interference from nearby electrical equipment.

### GROUNDING

The most fortunate minicomputer buyer is he who is planning an installation for a new building and, therefore, a new electrical power distribution system. The National Electric Code and most local codes specify grounding systems for the sake of plant and operator safety, and good practice in grounding for safety is also good practice from the stand-

point of minimizing electrical noise from the minicomputer's AC power source.

The branch circuit to the minicomputer's receptacle and the line cord set that connects the minicomputer to the receptacle each carry a safety ground wire, which is color-coded green, and carries no current except in the case of equipment malfunction. The minicomputer cord set also carries a white wire that is connected to earth ground, probably at the same point that the green safety wire is connected to earth ground, but the white wire is intended to carry current in normal minicomputer operation.

The green safety ground is connected to the metal frame of the minicomputer to prevent the accumulation of static charges that could endanger operating personnel. It also provides a return path for fault currents due to equipment malfunction or external faults such as lightning strikes. Even though the minicomputer is grounded according to the electrical code, the portion of the safety ground system used by the minicomputer is probably used for other pieces of equipment in the building. A fault in an unrelated piece of equipment which causes heavy current to flow in the safety ground system could have the effect of raising the potential of the minicomputer frame above the potential of earth ground. This creates a common-mode noise voltage between the minicomputer and peripheral equipment that may be located in other parts of the building.

Also, it is not unusual for the safety ground wire to be carried through hundreds of feet of conduit with other power wires, and to form a large antenna system that is capable of introducing noise into the minicomputer from sources such as air compressors, elevators, machine tools, and the like.

Emerson's new Tape Pac® System

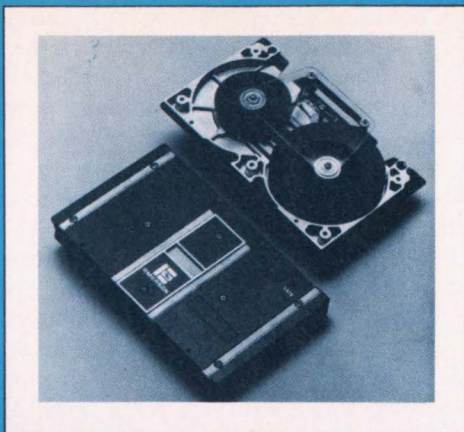

## A NEW STANDARD IN DATA STORAGE

Some of the most exciting and innovative systems now use our new 2000 Series Tape Pac®. With applications like cardiac analysis, fingerprint detection, interactive timesharing and data logging of nuclear power station efficiency.

The 2000 Series fits a significant gap in the market—above floppy disks and 3M cartridges, but below open reel tape drives. So we're readily finding market acceptance in major application areas such as source data entry, data communication terminal networks, and minicomputer or microprocessor systems.

We've combined a high performance tape drive with a Tape Pac® that uses 1/2-inch computer compatible tape. Providing a medium that for the first time protects tape in virtually any environment—computer or non-computer room. And is not susceptible to operator handling.

With the 2000 Series, you'll get a bi-directional read/write speed of 25 ips and a search/rewind speed of 240 ips. Available densities of 200, 556, 800, 1600 or 3400 bpi. 7 or 9 track NRZI, 9 track PE recording or a special recording format that's serial PE recording at 3400 bpi.



A standard Tape Pac® has 600 feet of 1/2-inch magnetic tape, (1000 feet optional), resulting in 12 or 20 megabytes of data storage. Basic transfer rate is 40K bytes per second.

Complete media protection is provided by spring-loaded dust doors that are only open when the pac is inserted in the drive.

You'll get a system that's plug to plug compatible with conventional tape drives that use industry standard tape formatters (PE or NRZI) . . . i.e. IBM or ANSI standards. With a choice of interfaces that include RS232, PDP-11, Nova Series and others. Higher reliability and longer

tape life. And the most effective overall cost/performance available anywhere.

Ask for more information. Better yet ask for a demonstration. See how we're providing a new standard in data storage and a unique concept in tape handling. From Emerson . . . a pioneer in tape handling concepts and magnetic recording techniques for more than 15 years.

Call Ron Carroll, Marketing Manager, (714) 545-5581. Or write Emerson Electric Co., ICD, 3300 S. Standard St., P.O. Box 1679, Santa Ana, Ca. 92702.

# EMERSON

CIRCLE NO. 15 ON INQUIRY CARD

The best safety ground for a minicomputer system is a separate ground connection, such as a metal water pipe or a metal ground rod driven into the earth, as close as possible to the physical location of the minicomputer. If such a connection can be made, then the green safety ground wire that accompanies the utility power lines should *not* be used for the minicomputer frame connection, since connecting the frame of the minicomputer to two separate grounding points creates a loop of grounding wires which allows inductive pickup of electrical noise.

In most applications, a minicomputer does not require special shielding. If safety grounding is properly carried out, radio frequency energy will be attenuated by the metal enclosure of the minicomputer. There are, however, occasions when a minicomputer is located near an airport, on a military installation, or in a radio or television broadcasting station and rf energy interference is an important noise source.

### AC LINE PROBLEMS

Obviously, many minicomputer installations are made in older buildings, and the installation planner does not have the luxury of specifying all that could be desired regarding system grounding. Also it is seldom possible to identify all of the potential sources of electrical noise and to isolate the minicomputer from them. Unfortunately, many of the symptoms that appear are mysterious and seemingly unrelated to the AC power source.

Following is a list of computer malfunctions that are often traced to an unstable AC power source. Because a transient power line disturbance often affects memory contents, these symptoms can appear either at the time of the disturbance or at a later time.

1. Computation errors
2. Inability to break out of a command loop
3. An unexpected branch or jump
4. An unexpected program halt
5. Reduced throughput rate
6. Inability to read data previously recorded on disk or tape

Malfunctions more closely associated with AC power problems include overheating, overvoltage, or undervoltage (including total loss of AC power). A prolonged overvoltage situation that leads to overheating can make a marked reduction in system reliability.

A serious power fluctuation lasting for about a half second causes a noticeable momentary dimming of electric lighting. Fluctuations lasting from three to 30 milliseconds are very common, and they are caused by utility power switching, by circuit breakers tripping, or by fuses blowing in nearby equipment. These power fluctuations are too short to have a perceptible effect on electric lighting, but they can cause severe malfunctions in a minicomputer system, principally in the transmission of data to or from the memory or peripheral equipment.

Another class of system problems caused by brief power line fluctuations is related to the nature of the power distribution system. The power lines serving the building have inductive and capacitive properties, and can be shocked into oscillations at resonant frequencies by voltage transients. The amplitudes and durations of these oscillations depend upon the rise time, the amplitude, and the duration of the transient. In an ordinary power distribution system, these oscillations may reach amplitudes of a few *kilovolts* and frequencies of *several hundred megahertz*. The oscillations

may continue for several hundred milliseconds, during which the amplitude, phase, and frequency characteristics of the AC power line are drastically altered. These transient oscillations may be transferred through the minicomputer power supplies in ways that were not foreseen by the system designer.

Some minicomputers have circuits which initiate a power-down sequence when a DC voltage moves out of tolerance for more than a few milliseconds. These voltage detectors are effective safeguards against a wide range of power transient problems, and operate to protect the system from the loss or distortion of data stored in memory. There are many cases, however, where the voltage detection circuits command a power-down sequence for a transient that poses no threat to the computer system. For example, the power fault may have potential effect only in a system peripheral device, but the voltage detection circuit shuts down the minicomputer system, causing an unnecessary interruption of service.

### REAL-WORLD EXPERIENCES

All of the power fluctuation problems that have been listed above can be caused by adjacent and unrelated equipment, and they are, therefore, outside the range of control of the utility company. Similarly, it is not possible for the minicomputer or peripheral manufacturer to anticipate all of the possible power fluctuation problems and provide protection means within the minicomputer to deal with the problems. It is also obvious that if every minicomputer were manufactured in such a way that it protected itself from every possible power anomaly, the cost of the minicomputer would be prohibitively high for almost every potential user. It is, therefore, economically necessary for the minicomputer user to create a "clean line" to the degree that will make his own minicomputer perform acceptably in his own power environment.

Table 1 provides a sense of the magnitude of the problem. It presents the results of a survey made using high speed fault counters to detect power fluctuations on the line voltage exceeding plus 10 percent or minus 8 percent of the

TABLE 1 — SURVEY OF LINE POWER FLUCTUATIONS

CATEGORY	TEST		DAILY	
	DAYS	HIGHS	LOWS	AVERAGE
Research	31	91	158	7
Bank	15	49	98	10
Insurance	14	58	109	12
Government	12	37	17	4
Manufacturer	211	—	—	7
Auto Leasing Firm	26	49	198	9

nominal 208 volts, lasting from two to 100 milliseconds. In the bank category, for example, over a period of 15 days, forty nine high voltage events and 98 low voltage events were recorded, for an average of 10 events per day. In the manufacturing category, the survey extended over a much longer period, but the equipment was not capable of distinguishing between high voltage and low voltage events. The records showed, however, that there were an average of seven power fault events in every working day.

Over the past several years, the term brown-out has been added to the jargon of business and industry. The term black-out has meant total loss of power at least since the time of World War II. Brown-out refers to an intermediate condition when the voltage is low, but not zero. There are many sources of the brown-out condition.

It is sometimes necessary for a utility company to deliberately lower the line voltage to accommodate an unusual power demand. In the eastern part of the United States, this condition often occurs during the peak of the summer air conditioning season. If the minicomputer system continues to operate during a brown-out, it is at least true that most of the safety margins provided by the minicomputer designer are reduced.

A brown-out condition is often produced by installation of new equipment in an older building having an inadequate power distribution system. The inadequacy may be entirely within the building, or it may be in the service drop from the utility company's transformer to the building entrance. This sort of low voltage condition can change drastically throughout the operating day, as various electrical equipments are turned off and on.

#### THE REMEDIES

There are three ways for a minicomputer user to create a "clean line" completely under his control. The three ways differ in cost, depending upon the severity of the problem.

In an installation where the only significant AC power problem is noise generated by the switching of nearby or adjacent equipment, the super-isolation transformer will provide a suitably clean line. The super-isolation transformer has specially constructed shielding on the primary and the secondary windings to provide a maximum of isolation from common-mode effects, and is about 1000 times more effective than ordinary isolation transformers in reducing the amplitudes of common-mode noise voltages transferred from primary to secondary. The super-isolation transformer is more expensive than the conventional isolation transformer, but its cost is negligible compared to the losses generated by just one minicomputer system failure due to an AC power line noise event.

A minicomputer installation that is threatened by brown-outs must be protected by a line conditioner. There are several line conditioners on the market, but the best ones provide rejection of switching noise comparable to the super-isolation transformer, in addition to regulation against line voltage changes; when the primary voltage of the line conditioner varies over a wide range, its secondary voltage remains relatively constant. Many devices sold as line conditioners provide this regulation against primary voltage changes, but they provide no isolation from the utility line or switching noise suppression because they incorporate autotransformers, which do not have separate primary and secondary windings. The most economical line conditioner uses a ferro-resonant transformer that incorporates the shielding techniques of the super-isolation transformer to provide safety isolation from the utility line, suppression of the switching noise generated by other equipment, and regulation against primary voltage changes.

The next step in complexity and cost is the uninterruptible power system (UPS). The UPS affords protection against switching noise, brown-outs, and black-outs. It consists of a battery charger, a battery, and a DC to AC inverter. The minicomputer is connected to the inverter output at all times, and so it is powered by the battery rather than the

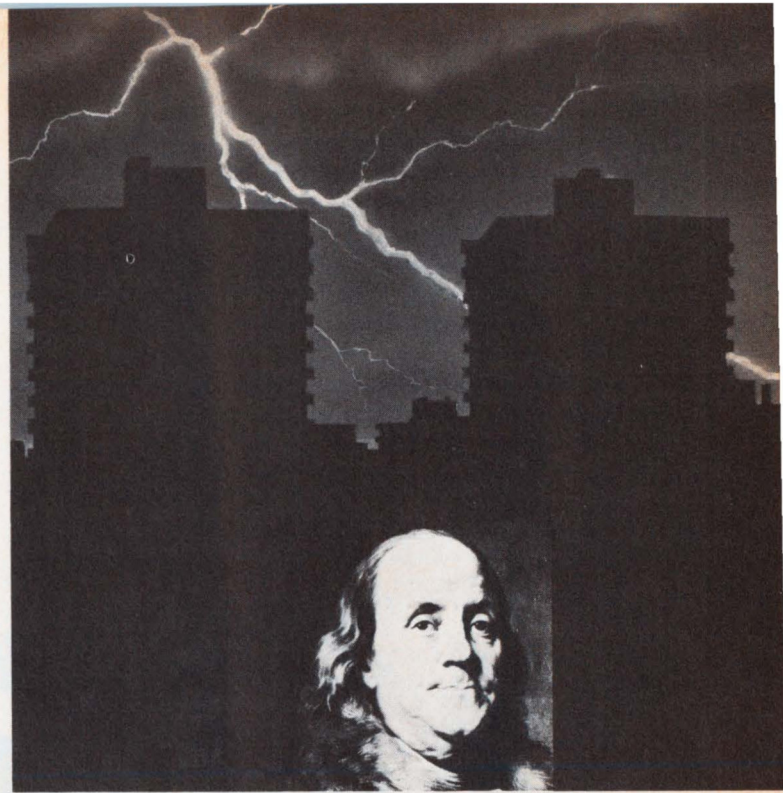

## Ben's lightning rod can't protect your computer from power failure shutdown... but we can.

Thunderstorms cause frequent power interruptions that last but a few seconds . . . with a resulting computer shutdown of many hours before processing can be resumed. And there's always the risk of another "hit".

Because of that tiny power break, your firm loses profit opportunities. Information flow has ceased . . . no orders are entered, no inquiries are received, no deliveries are quoted. These lost opportunities, plus the cost of rerun and possible equipment damage, can make those few seconds very expensive.

Eliminate power disturbances with an Uninterruptible Power System (UPS) from International Power Machines Corporation.

There are over 500 IPM systems throughout the world protecting virtually every kind and size of computer. You can profitably learn how our customers benefit from these installations.

Find out also how IPM's advanced technology has greatly reduced UPS costs!

Write today for the brochure, "Uninterruptible Power Systems: A Management Overview".



**International Power Machines Corporation**  
3328 Executive Blvd. • P. O. Box 724 • Mesquite, Texas 75149  
214/288-7501 • Telex: 73-0992

utility AC line. The AC line is used to charge the batteries when it is present; and when it is absent, power flows from the batteries to the inverter. The uninterruptible power system provides safety isolation, suppression of switching noise, regulation to eliminate the effects of brown-outs, and energy storage to eliminate the effects of black-outs. Unless the black-out duration exceeds the capacity of the battery set specified by the minicomputer user, the minicomputer is exposed only to the output of the UPS inverter. It is, therefore, very effectively decoupled from the vagaries of the AC power distribution system.

The most sophisticated uninterruptible power systems are designed to sense failures within the UPS itself and automatically transfer the minicomputer to the utility line in the event of an overload or a UPS failure. This rather inex-

pensive redundancy greatly improves system reliability.

Over the past ten years computers have grown smaller and smaller while computer control systems have grown larger, more complex and more critical to the conduct of human affairs. The heavy demands of our growing technology on the power distribution system have created problems in the quality of power, and the increasing speed of computers makes them less tolerant of power system aberrations.

We have described a number of solutions to power system problems and we have shown that there is some flexibility in cost, depending upon the nature of the problem. As computers and their power requirements continue to shrink, it is economically feasible to consider the power conditioning equipment that we have described for a very wide range of system sizes.

# tracking down and identifying power line aberrations

ABRAHAM I. DRANETZ, President, and MELVIN DIETTMANN, Project Engineer / Dranetz Engineering Labs, Inc., South Plainfield, NJ

The designers and operators of today's sophisticated electronic equipment can exercise tight control over just about every factor in their systems except the quality of the commercial power lines. Even though power companies make a strong and continuous effort to maintain the voltage, frequency, and waveform on their lines within acceptable standards, there are practical and economic limitations. For example, customers using power from these lines connect and disconnect large loads at random, creating sudden sags and surges in the local line voltage, as well as random spikes and notches. There is no practical means for a power company to compensate for these local aberrations, nor can it eliminate the transients caused by lightning hits or faulty switching.

Most electronic equipment is designed to operate consistently despite reasonable fluctuations and noise on the AC line from which it draws its power: the big hitch is in the definition of "reasonable." It can be assumed that the equipment designer has done an intelligent and conscientious job in designing the internal DC power supplies, consistent with the economic limits assigned. But in the absence of a proprietary source of AC power, or interposition of an uninterruptible power supply, available commercial power lines may not meet the designer's definition of "reasonable," and here is where the big arguments arise — whose responsibility is it: the equipment manufacturer's, the user's, the servicing organization's, or is the AC line quality simply so poor that none is to blame?

Arguments about power-line culpability can be settled only by direct monitoring and analysis of the performance of the power line in question. Synthetic testing of computer performance is not conclusive, nor is real-time oscilloscope observation of the line voltage. Even an exhaustive tabulation and analysis of miles of strip-chart recordings will not provide the complete, peak, worst-case, cycle-by-cycle data

that fully defines the line performance. *All* deviations from ideal behavior must be detected, recorded and analyzed.

Minicomputers are extremely sensitive to power disturbances because the users can rarely justify the cost of a dedicated power line and/or an uninterruptible power supply. Typically, a user who is experiencing problems with minicomputer performance will call the manufacturer's local customer service office for assistance. With suitable power line analysis, the field service engineer can very quickly either identify or eliminate poor power quality as the source of his customer's problem. If the AC power is found to be adequate, the field engineer can then proceed with the equipment check-out until the cause of the malfunction is located. If, however, the AC power is judged too poor for proper minicomputer operation, the field engineer can present his customer with hard copy proof. The alphanumeric description of each disturbance, along with the time of occurrence, are easily understood by even the least engineering-oriented user.

Quite often, the field engineer will leave an analyzer on the AC line for several days with the minicomputer running. Whenever the minicomputer malfunctions or shuts down, the exact time may be noted and compared with the disturbance record printed by the analyzer. This provides further convincing proof that poor power quality is the culprit.

Finally, the analyzer is most useful in assisting the field engineer with his recommendations for corrective actions to ensure that adequate AC power is supplied to the minicomputer in the most economical way. The statistical accumulations presented by the analyzer indicate the frequency and severity of various types of power line disturbances that must be overcome by the corrective measures.

Let us examine the various types of line aberrations that must be dealt with:

**Surges and Sags.** These are rapid changes in the amplitude of the AC line voltage sine wave, persisting for an appreciable fraction of one cycle, or for a number of cycles, without significant alteration of the waveform.

**Slow-Average Fluctuations.** Slow variations in the RMS voltage value of the sine-wave, measured over an appreciable time interval (e.g., 10 seconds).

**Transient Impulse.** These are deviations from the ideal AC sine wave having a very short duration compared with one cycle — typically from a fraction of a microsecond to several milliseconds. Their forms range from single pulses with extremely short rise time and exponential decay to

typical equipment, each block has been marked to indicate the types of line aberrations to which it is normally sensitive.

In most computers, the magnetic-core memory is protected against loss of data during power interruptions, by automatic circuitry that manages an orderly shutdown of read/write functions whenever the line is interrupted for more than a half cycle or so. But it can be caused to record an error in response to a sufficiently large transient, and marginal cores and sense amplifiers can “drop a stitch,” or read or write a ONE which should have been a zero, as a result of large sags and surges. Then there is the problem of temperature. Since most of these memories are quite sensi-

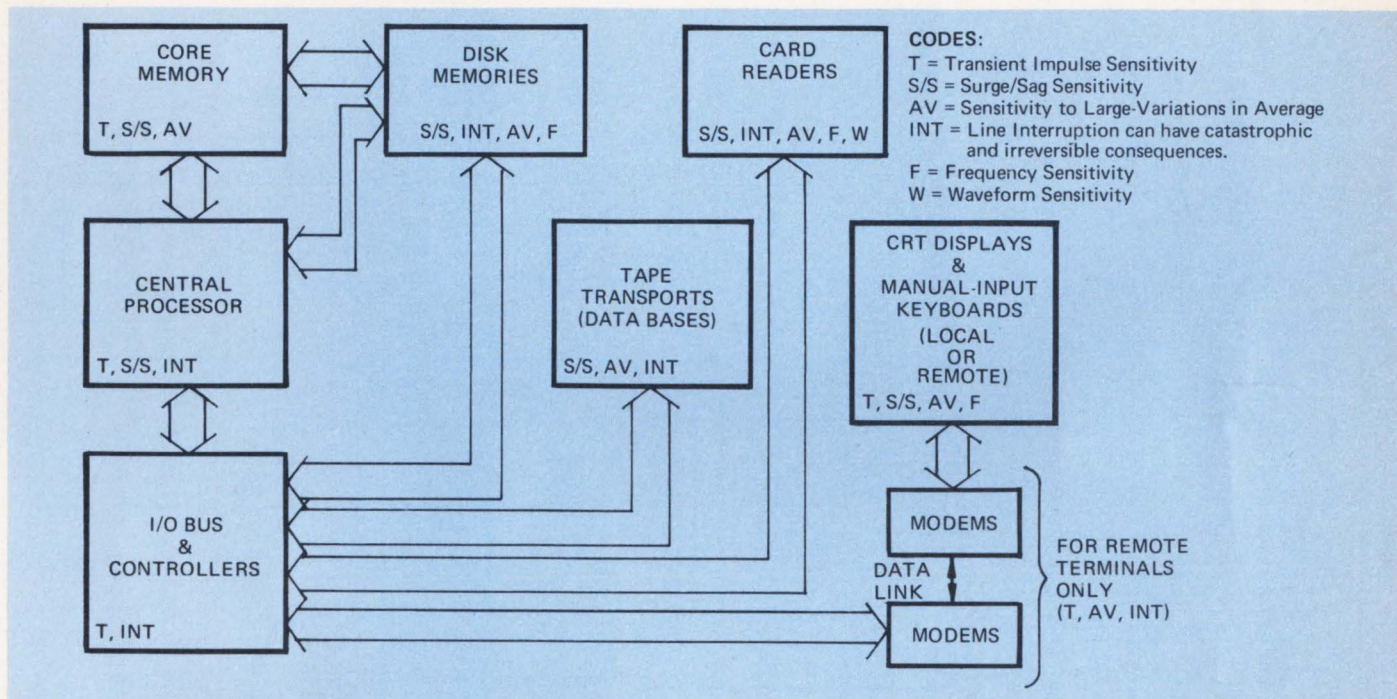

Fig. 1 — Computer installation indicating line-aberration sensitivities

oscillatory disturbances persisting for five to ten oscillations within an exponentially decaying envelope. They may either increase or decrease the instantaneous amplitude of the sine waveform, described as a “spike,” or “notch” respectively.

**Line Interruptions.** These are instants when the line voltage sags to zero. Conventionally considered to be an absence of line voltage for an interval ranging from several seconds to hours or even days. It should be realized, however, that dropouts as short as one cycle are quite common, in even the most reliable power lines.

**Frequency Variations.** Changes in the period of the power-line sine wave, averaged over thousands of cycles.

**Waveform Variations.** Persistent cyclic changes in line waveform that do not affect the average amplitude, and are independent of frequency variations, sags, surges, and transients. For example, second-harmonic distortion, which does not necessarily change the amplitude of the waveform envelope, nor the average value of the rectified wave, but does change the RMS, or heating, value as well as the crest factor.

Obviously, if the excursion is large enough, or if the design of the equipment’s DC power supplies is marginal enough, every one of the above aberrations can cause trouble in any computer application. In the representative computer system shown in Fig. 1, each functional block could exhibit any degree of sensitivity to these line aberrations from total vulnerability to complete independence, depending on the power supply design. On the basis of the sensitivity of

tive to temperature, ambient-temperature sensors are used at the stack to provide feedback signals to the power supply, to raise or lower the drive current levels for compensations against ambient fluctuations. Prolonged high or low line-

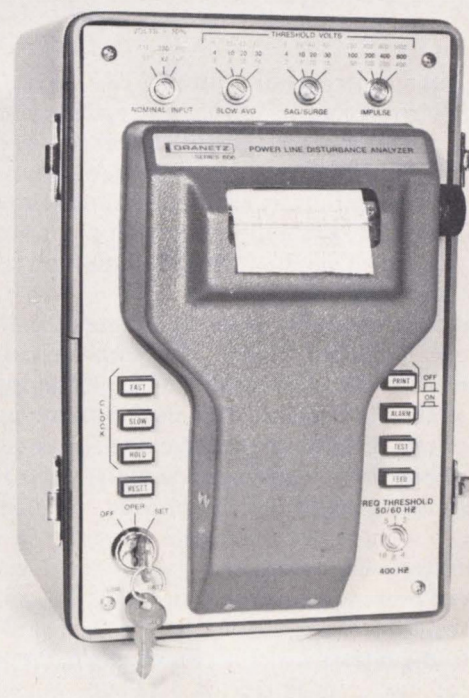

Fig. 2 — A power line disturbance analyzer (Dranetz Model 606)

voltage excursions of excessive magnitude can run the compensation circuitry completely out of range, or a high line condition can eventually overheat the equipment enclosure beyond the highest compensatable temperature.

In the central processor, on the other hand, data guarding is very difficult to implement, and since the power supplies provided for this section usually are unable to sustain operation for more than 10 or 20 milliseconds after an interruption of line power, dropouts can cause the CPU to make many kinds of errors. It is not normally troubled by slow line variations, but it is likely to respond improperly to line transients and severe sags or surges.

variations system? Yet, in theory at least, one "glitch" at the wrong time, in the wrong place, could do it.

The need for good line quality is universal; some equipments can tolerate poorer line quality than others, but there are always limits. What these limits are, whether they have been exceeded or not in a given installation, what to do about it if they have, and who is to do it, are great areas for argument.

In some situations, the line quality is so high, and so consistent, that it is only necessary to verify it, and enjoy it. In other cases, it is just as clear that the line quality is so poor and undependable that the only recourse is the instal-

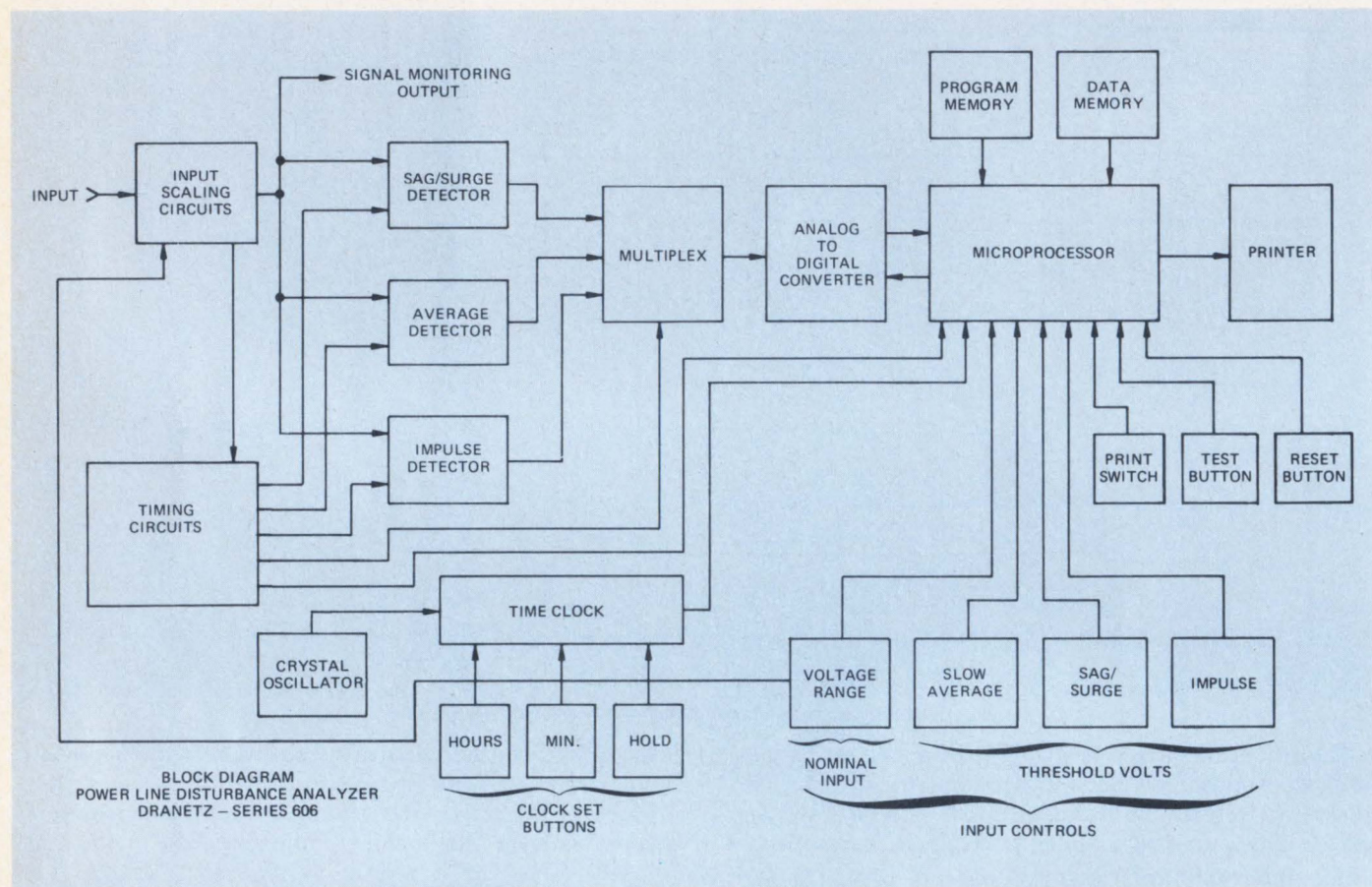

Fig. 3 - Analogic functional block diagram

The I/O bus and peripheral controller circuits can usually be thoroughly protected by regulation against most slow-average, sag, surge, and crest-factor influences, since they have only modest power requirements. However, the regulating circuitry conventionally used here is usually vulnerable to transients and line interruptions, resulting in errors, data losses, and the chaos produced by disruption or failure of the priority interrupt system.

Disk memories may be relatively immune to transient impulses, but long-term average, sag/surge, interruption, and frequency variations all influence the critical speed and timing constraints imposed in data-block positioning, interlacing, and access time for retrieval. Some of these problems have been eliminated by advanced-design systems that use clock-pulse-servoed speed synchronization for fixed-head disk drives, but most disk memories currently in use are quite vulnerable to line variations.

The cost of power-line misbehavior can be staggering. An hour of down-time can easily run to five figures. But who can estimate the ultimate cost of, for example, the accidental erasure of just a single reel of data-base storage in an insurance company's accounting system, or an airline's reser-

vation of uninterruptible power supplies at all points, plus fail-safe design in all areas vulnerable to malfunction or data-loss in the course of impulse penetration, interruption, or emergency shutdown. In the vast majority of situations, however, there is only one way to settle all arguments about power line quality, and that is by detailed, exhaustive measurement, recording, and analysis of the performance of the power line in question, over a definitive interval of time. Instruments to perform this function are now available in compact, efficient, standard monitoring instruments. An example is the portable line-monitoring instrument shown in Fig. 2, which performs all of the amplitude-type measurements, and could be custom modified to provide the frequency and waveform measurements as well. It is 11" high, weighs about 15 pounds, and is available in single-input or three-input models, for monitoring single-phase or three-phase delta or wye power lines, at selectable nominal voltages of 115, 230, or 460 Vrms ( $\pm 50$  percent).

Fig. 3 shows a functional block diagram of the instrument, simplified to represent the measurement circuitry monitoring a single phase of the power line (INPUT). The input is scaled in accordance with the setting of the front-

# Introducing The UPSables for '76

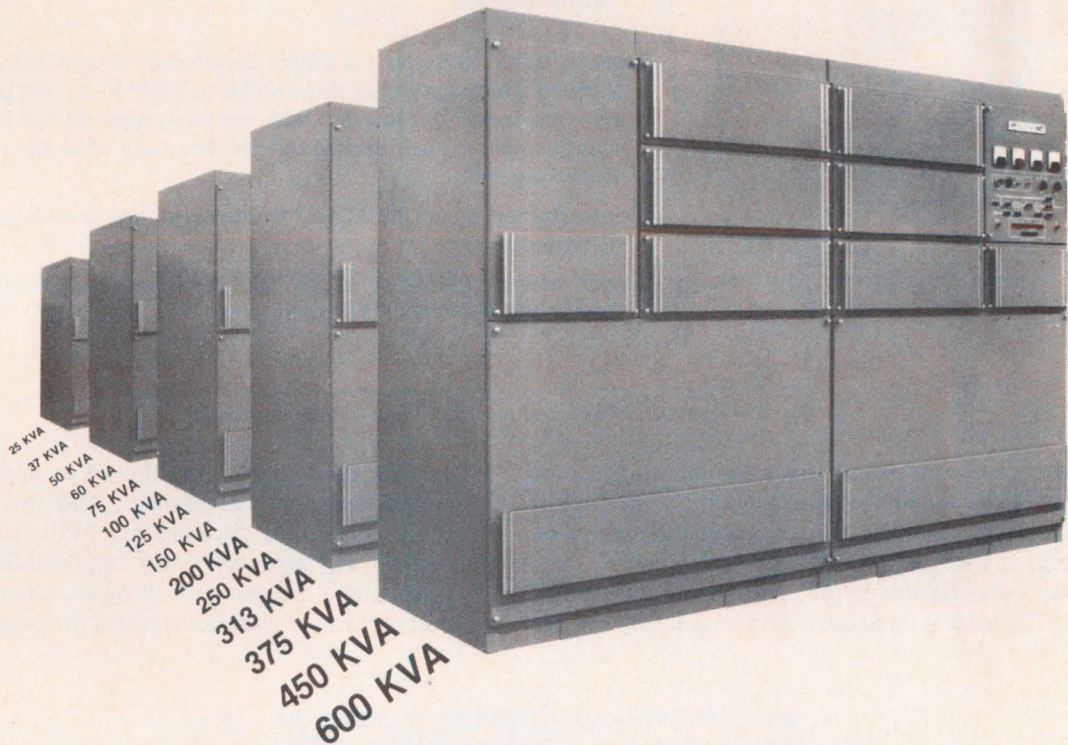

Teledyne Inet, the precise power people, introduces its 4th Generation of Uninterruptible Power Systems . . . the UPSables for '76.

Specifically designed to interface with your computer / data processing system, our new family of solid-state UPS offers the highest efficiency and greatest reliability in 60 Hz, 50 Hz, and 415 Hz precise power.

Available in module ratings of 25 KVA to 600 KVA, each system can be configured to meet your specific power requirements. With the highest efficiencies of up to 91%, and the most compact system designs, you'll save in operating, cooling, and installation costs.

Whether your application calls for solid-state Uninterruptible Power Systems, Frequency Converters, or rotary equipment, Teledyne Inet has the protection your computer needs against power fluctuations, brownouts, and blackouts.

We're celebrating the biggest revolution in Uninterruptible Power Systems ever!

For more information, write Teledyne Inet, Marketing Department, Uninterruptible Power Systems, 711 West Knox Street, Gardena, California 90248, or call area code 213-327-0913.

**TELEDYNE INET**  
... the precise power people

CIRCLE NO. 17 ON INQUIRY CARD

panel VOLTAGE RANGE switch, to one of three nominal ranges. Simultaneously, this range-setting information is fed (in digital form) to a microprocessor to permit correct interpretation and printout of measured values.

(TEST) summaries make it unnecessary to tediously search for worst-case conditions, yet the detailed recordings are available for moment-by-moment inspection and analysis of specific occurrences, and intermediate cycles. The time

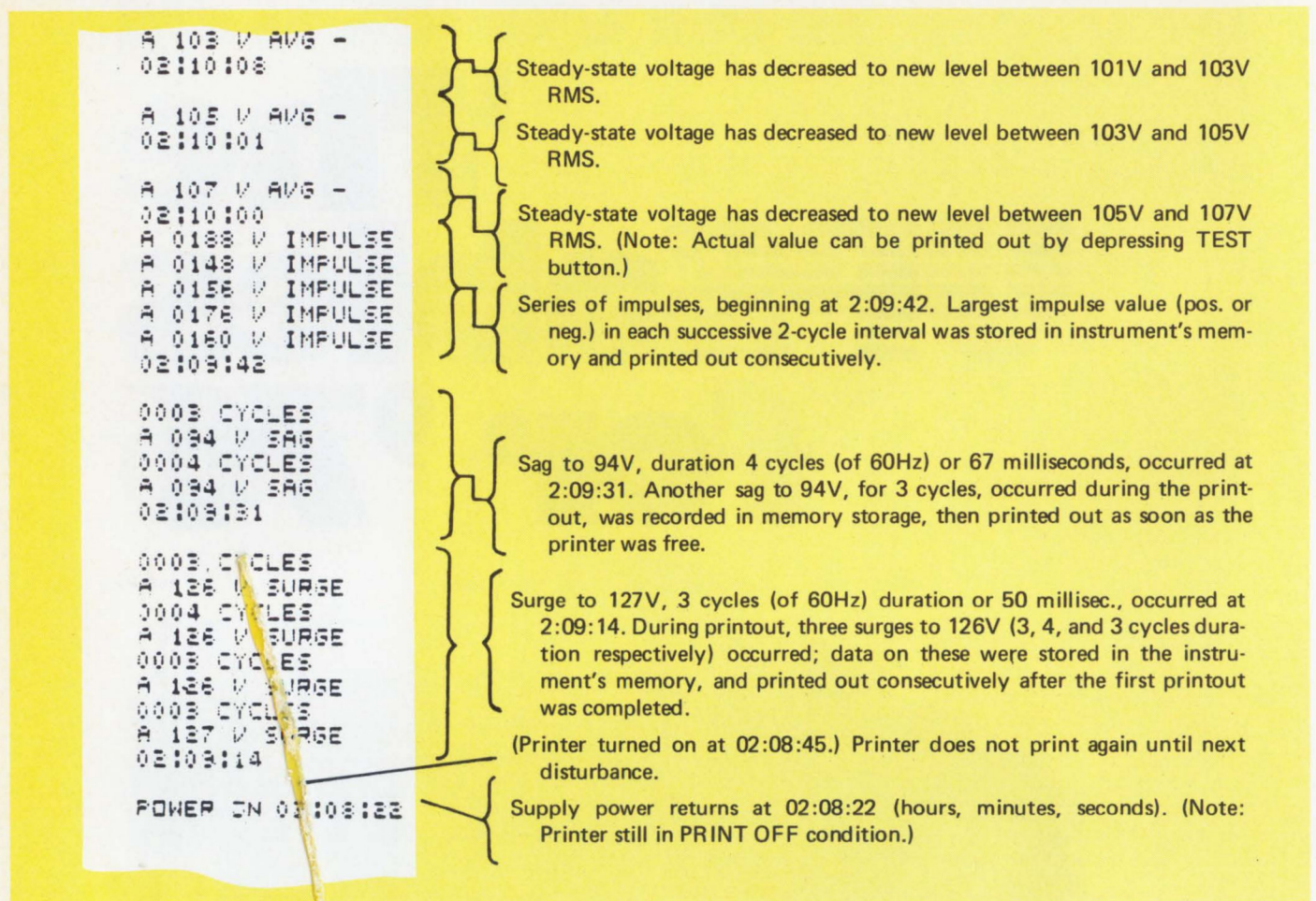

Fig. 4 - A section of a typical record printout with interpretation

A typical record printout of this instrument appears in Fig. 4. It should be noted that the direction of motion of the tape as it issues from the printer causes the earliest reports to appear at the *bottom* of the strip.

Daily and weekly records can be accumulated and studied at small cost. The automatic summaries, and arbitrary interim

identifications enable matching of equipment malfunctions to individual line disturbances. And the complete printed record constitutes documentary evidence for settling conclusively any arguments over responsibility for equipment misconduct, between the designer, the manufacturer, the user, the service organization, and the power company.

# EFFICIENCY— Key to UPS selection

R.L. COOPER / President, Franklin Electric, Programmed Power, Inc., Menlo Park, CA

System conversion efficiency has been a key factor in the procurement specifications of recent UPS procurements. The Social Security Administration issued recent IFB's for UPS systems calling for a given efficiency, and the supplier would be penalized or rewarded depending on whether the equipment efficiency tested below or above the specified percentage. The National Bank of Alaska recently purchased a UPS system with the requirement that, for each percentage point below the required minimum efficiency, a penalty

of \$20,000 be deducted from the purchase price. GTE Data Services required a life cycle cost model, in which efficiency was a key factor, in their procurement for UPS and frequency converters. The State of Nevada purchased a large UPS with the determining factor being efficiency.

High efficiency of power conversion means low inefficiency, inefficiency is the percentage terminology for loss of energy or waste, and lost power due to inefficiency must be paid for and it can never be recovered. As a matter of fact,

# PROGRAMMED POWER...

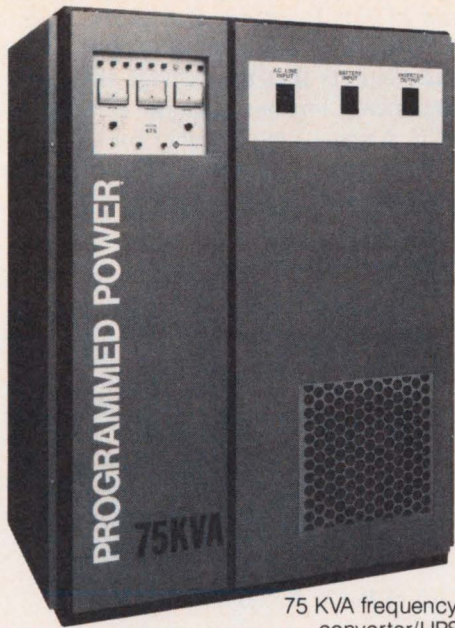

75 KVA frequency converter/UPS

Beginning with sensitive Power Line Disturbance Monitors, then high-efficiency power frequency converters, UPS, and power conversion systems, PPI offers a broad capability in power problem detection and power problem solving.

PPI was first to offer Power Line Disturbance Monitors to characterize your problems on DC, 50, 60, 400, 415 and 441 Hz mains. PPI was first again with Transient Direction Detection to determine the source of your transients—and first once more with an 89%-efficient 400 Hz, 75 KVA frequency converter/UPS. Now, PPI offers advanced designs in 50 -150 KVA UPS. For the future—an even broader capability in Disturbance Monitors and power conversion systems.

- 50 - 441 Hz Power Line Disturbance Monitors
- 75 KVA Frequency Converters/UPS
- 50 KVA UPS
- 75 KVA UPS
- 100 KVA UPS
- 125 KVA UPS
- 150 KVA UPS



Power Line Disturbance Monitor



**Franklin Electric**

Programmed Power Inc., 141 Jefferson Drive, Menlo Park, Ca 94025 (415) 323-8454

CIRCLE NO. 18 ON INQUIRY CARD

inefficiency is usually a devil wearing many disguises creating multiple, tangible and intangible problems.

First, lost power due to inefficiency costs real money — a tangible. Second, the lost power is converted to heat which usually is removed by air conditioning or some other cooling technique and, therefore, represents an additional cost. Heat is the worst enemy of solid state componentry, and thus, the greater the heat generation the shorter the life of the components before failure. The more heat generated within a power converter, the larger in physical size the converter must be to dissipate the heat. The larger in physical size, the greater requirements for expensive real estate to house the converter.

The Federal Government is making a strong case for the conservation of energy. Defense Procurement Circular, DPC No. 75-1, 30 July 1975, Item VI is entitled ENERGY CONSERVATION. It states in part:

“The energy problems facing the United States are of equal concern to the Federal and private sectors of our Nation. Although the total energy consumption of the Department of Defense is a small percentage of the total energy consumption the Federal Government and its contractors must set an example for the rest of the Nation in conserving our energy resources.

“The Secretary of Defense has directed that vigorous conservation measures be taken by the Department of Defense. Defense contractors are hereby requested to implement energy conservation measures. Such measures shall be consistent with contract performance and can include . . . the implementation of specific plans for reducing energy consumption in lighting, heating, air conditioning as well as in industrial operations and processes . . .”

The cost of wasted energy due to inefficiency of power conversion is sufficient reason unto itself for specifiers of equipment to concern themselves with efficiency. In past years when electricity was plentiful and cheap, a specifier probably thought that a 5 percent differential in the efficiency of two power converter systems was negligible. Too infrequently did he think in terms of inefficiency or lost power. For instance, two power converters having efficiencies of 85 percent and 90 percent still have a 5 percent differential in efficiency. But now consider their inefficiencies: the 85 percent machine wastes 58.82 percent more power than the 90 percent machine!

In the comparison of an 80 percent and a 90 percent system, the 80 percent system wastes 125 percent more energy than the 90 percent system! If this seems incredible, perform the simple mathematical computation and become enlightened.

Consider the formulae involved:

$$\text{Efficiency (\%)} = \frac{\text{Power Out}}{\text{Power In}}$$

Lost power due to inefficiency is expressed as,

$$\text{Power (Loss)} = \text{Power (In)} - \text{Power (Out)}$$

If the required  $P_{out}$  is unity, then the required  $P_{in}$  for the 85 percent system is:

$$\frac{1}{0.85} = 1.17647$$

and the wasted portion is:  $1.17647 - 1.00000 = 0.17647$ . For the 90 percent system,

$$P_{in} = \frac{1}{0.90} = 1.11111$$

and the wasted portion is  $1.11111 - 1.00000 = 0.11111$ . Comparing the wasted portions,

$$\frac{0.17647}{0.11111} = 1.58815$$

i.e., the 85 percent system dissipates 1.58815 times or 58.815 percent more heat than does the 90 percent system!

### REFERENCE LITERATURE

For more information on all or any of the following manufacturers' power equipment, circle the appropriate number(s) on the reader inquiry card opposite the back cover.

#### UNINTERRUPTIBLE POWER SYSTEMS (UPS)

COMPANY	READER INQUIRY NO.
Advance Conversion Devices, Passaic, NJ . . . . .	51
Airoyal Development, Co., Fairfield, NJ . . . . .	52
Cyberex Inc., Mentor, OH. . . . .	53
Deltec Corp., San Diego, CA . . . . .	54
Elexon Power Systems, Santa Ana, CA . . . . .	55
Elgar Corp., San Diego, CA . . . . .	56
Emerson Electric, Santa Ana, CA . . . . .	57
ESB/Exide Power Systems, Philadelphia, PA. . . . .	58
General Electric/GPCBD, Bloomington, IL. . . . .	59
Gould/Industrial Battery Div., Burlington, MA . . . . .	60
Instrumentation & Control Systems, Addison, IL . . . . .	61
International Power Machines Corp., Mesquite, TX . . . . .	62
Lorain Products, Lorain, OH . . . . .	63
Nova Electric Co., Nutley, NJ . . . . .	64
Power Systems & Controls, Richmond, VA . . . . .	65
Precise Power Corp., Bradenton, FL . . . . .	66
Programmed Power, Menlo Park, CA. . . . .	67
Solidstate Controls, Columbus, OH. . . . .	68
Standby Systems, Medford, MA . . . . .	69
Static Power, Newport Beach, CA. . . . .	70
Teledyne Inet, Gardena, CA . . . . .	71
Terado Corp., St. Paul, MN . . . . .	72
Topaz Electronics, San Diego, CA. . . . .	73
Total Power Corp., Framingham, MA . . . . .	74
Unitron Inc., Garland, TX. . . . .	75

#### LINE CONDITIONERS & VOLTAGE REGULATORS

Airoyal Development Co., Fairfield, NJ . . . . .	76
Control Systems, Inc., Deer Park, NY . . . . .	77
Creigier Electrical Mfg., Chicago, IL . . . . .	78
Cyberex Inc., Mentor, OH . . . . .	79
Deltec Corp., San Diego, CA . . . . .	80
Electro Engineering, San Leandro, CA. . . . .	81
Elgar Corp., San Diego, CA . . . . .	82
Frequency Technology Inc., Littleton, MA. . . . .	83
Instrumentation & Control Systems, Addison, IL . . . . .	84
Nova Electric Co., Nutley, NJ . . . . .	85
Power Systems & Controls, Richmond, VA . . . . .	86
Precise Power Corp., Bradenton, FL . . . . .	87
Sola Electric, Elk Grove Village, IL. . . . .	88
Topaz Electronics, San Diego, CA. . . . .	89

#### POWER LINE MONITORS

Airoyal Development, Co., Fairfield, NJ . . . . .	90
Dranetz Engineering Labs Inc., So. Plainfield, NJ. . . . .	91
Holland Electronics, Inc., Brooklyn, NY . . . . .	92
Power Systems & Controls, Richmond, VA . . . . .	93
Programmed Power, Menlo Park, CA. . . . .	94

Now, for a more dramatic effect of the efficiency differential, let us convert this lost energy to costs in dollars. Costs for electricity vary throughout the nation, but a government user in Port Hueneme, California, reports electricity costs \$0.0401/kWh while an employee of the City of Austin, Texas, reports that they charge their customers in excess of \$0.05/kWh. For our example, consider the cost to be \$0.04/kWh. Assume a requirement for UPS to output continuously 100 kilowatts of power. The cost of wasted power per year can then be expressed by the formula;

$$\begin{aligned} \text{Cost of } P_w \text{ (in \$ )} &= \\ &= \left[ \frac{100 \text{ kW}}{\text{efficiency}} - \frac{100 \text{ kW}}{100 \% \text{ efficiency}} \right] \times \$0.04/\text{kWh} \times 8760 \text{ hrs/yr} \\ &= 0.04 \times 8760 \times 100 \left( \frac{1}{\text{eff}} - 1 \right) \\ &= 35,040 \left( \frac{1}{\text{eff}} - 1 \right) \end{aligned}$$

For the 85 percent system,

$$\begin{aligned} \text{Cost of } P_w &= \$35,040 \left( \frac{1}{.85} - 1 \right) \\ &= \$6183.53 \text{ per year} \end{aligned}$$

For the 90 percent system,

$$\begin{aligned} \text{Cost of } P_w &= \$35,040 \left( \frac{1}{.9} - 1 \right) \\ &= \$3893.33 \text{ per year} \end{aligned}$$

The 5 percent differential in this example represents an additional annual cost of electricity of \$6183.53 - \$3893.33 = \$2290.20!

So far, the cost of removing the extra heat generated hasn't been considered. Since UPS are often installed in an air conditioned environment, many times a computer room, additional air conditioning capacity is required to remove the extra heat. Air conditioning contractors advise that a typical form factor of 3 is used; i.e., one part of electricity is required by air conditioning to remove the heat generated by three parts of electricity. So, the cost differential of \$2290.20/yr should be increased by a third to \$3053.60/yr.

Neglecting the probable increases in electricity rates, the interest on the capital investment, the possible utilization of some of the heat generated, etc., and; assuming a 10-year life of the system, the cost differential for the two systems used in this example has now reached \$30,536.00 - a significant amount for anyone's budget. The 10-year differential between the 80 percent and 90 percent systems is \$64,873! No attempt will be made here to estimate the probable increase in maintenance and repair costs of the 85 percent system over the 90 percent system; nor for the cost of the increased space utilization, but these factors become important in a life cycle cost analysis.

The example cited dramatizes the importance of efficiency as a key factor in life cycle costs of power converters, however, efficiency considerations should not be limited simply to power converters.

Inefficiency in small equipment as well as large machines should become an element of the decision-making process prior to procurement. Examples can be cited where the differential costs of power during the life of a system exceeds the initial cost of the equipment itself. Initial cost, installation costs, service,

maintenance, MTBF, MTTR, life expectancy, and salvage value should all be considered in performing a life cycle cost analysis. But the efficiency differential is likely to represent the greatest variable.

There are efficiency *traps*! The power converter specifier should be forewarned! Normally, UPS systems are specified to have a full-load output power rating which exceeds the nominal operating load by 35 percent to 75 percent or more. UPS manufacturers typically spec their system's efficiency at full-load without providing data at partial loads. The efficiency degradation at fractional loads can be very consequential. The specifier would do well to require bidders to state the proposed system's efficiency at 25 percent, 50 percent, 75 percent and 100 percent full-load. He should also require a statement of no-load losses, which will provide

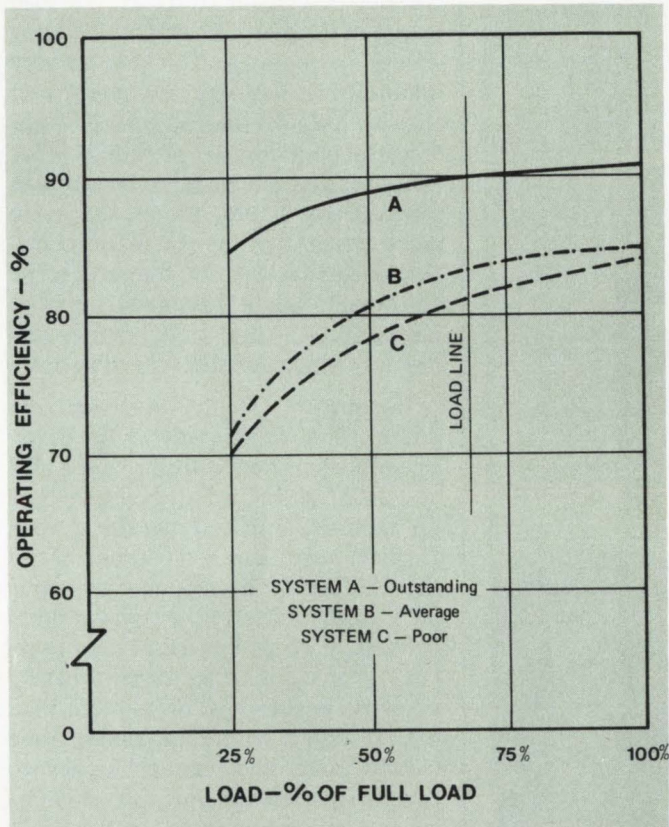

Fig. 1 - Efficiency deterioration curves for three systems from 25 percent to 100 percent of full load. Note rapid deterioration in efficiency of Systems B and C at fractional loads. System C is typical for the better motor-generator frequency converters.

an important clue to prospective "hot spots" within the system. When fractional efficiency ratings are provided, the specifier can plot a simple efficiency deterioration curve similar to that shown in Fig. 1.

He can then determine where his nominal load would fall and see graphically the difference at his particular load line. Then, after graphically determining the operating efficiency at the expected load for each system under consideration, he can quickly apply the formula for *inefficiency*:

$$\text{Inefficiency} = \frac{1}{\text{eff}} - 1$$

to determine the percentage of input power required over the power outputed to his load. Comparing the relative inefficiencies at **nominal** operating loads can be very enlightening.

If the specifier neglects to perform this simple analysis, but only insists that full-load efficiency data be provided, he may fall into another serious trap - *efficiency peaking*. Some inverter designs permit changing the magnetics in the output filter to provide peak efficiency at a given load, but



THE  
RELIABLE SOURCE  
FOR  
UNINTERRUPTIBLE POWER



PRICES START AT \$1650.00

AVAILABLE IN SINGLE PHASE RATINGS FROM 625 VA TO 5 KVA

**CLARY CORPORATION**  
320 W. Clary Avenue  
San Gabriel, California 91776

PHONE (213) 287-6111

CIRCLE NO. 19 ON INQUIRY CARD

COMPUTERS NEED

**U.C.P.\***

SYSTEM  
700UCP  
PROVIDES

- "BROWN-OUT" PROTECTION
- VOLTAGE CONTROL
- FREQUENCY CONTROL
- TRANSIENT CONTROL
- LINE ISOLATION
- BRIDGES UTILITY POWER INTERRUPTIONS

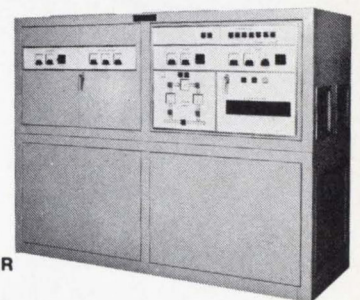

\*UNINTERRUPTIBLE  
**COMPUTER POWER**

Call Anna Moore (804) 355-2803 OR WRITE



**POWER SYSTEMS  
& CONTROLS, INC**

P. O. BOX 27306 • RICHMOND, VIRGINIA 23261

CIRCLE NO. 37 ON INQUIRY CARD

# UNINTERRUPTIBLE POWER

from the Industry Leader

Topaz Uninterruptible Power Systems are in operation throughout the world supplying ac power to computers, process control systems, medical equipment and other critical loads.

If you need uninterruptible power, a Topaz UPS can best fill the need. Here's why:

- **HIGH RELIABILITY** through conservative design.
- **HIGH EFFICIENCY** resulting in lower operating costs, reduced heat losses, and lower battery costs.
- **EXCELLENT NOISE SUPPRESSION** protects against line transients and spikes.
- **HIGH INPUT POWER FACTOR** reduces installed cost.
- **FRONT PANEL DIAGRAM** permits monitoring UPS status.
- **FAST BATTERY RECHARGE** improves system backup capacity.
- **SYSTEM BYPASS FEATURE** improves personnel safety.

And these are only a few of the reasons. If you'd like more information about Topaz Uninterruptible Power Systems, send for our literature or phone us at (714) 279-0831.

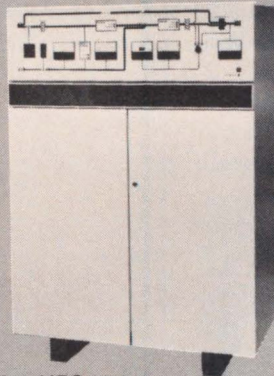

**TOPAZ** SOLUTIONS TO POWER PROBLEMS  
ELECTRONICS

3855 Ruffin Road, San Diego, California 92123—(714) 279-0831—TWX (910) 335-1526

CIRCLE NO. 20 ON INQUIRY CARD

as the load varies, the efficiency drops, and the output waveform purity may contain harmful harmonics which the load may not tolerate. Obviously, it would be a false sense of security to purchase UPS having good efficiency and waveform purity at full-load and have both go to hell in a hand basket at the operating load of 60 percent of full-load.

Another trap could be the specifier accepting the manufacturer's word on supplied UPS equipment specifications without witnessing tests at the load levels of interest: acceptance testing should be required. This can be very important in assuring the system user that his load will indeed operate satisfactorily on the power provided by the UPS over the anticipated operating load range. Care should also be taken to make certain that the test instrumentation is satisfactory for the tests to be performed. Simple watt meters may be insensitive to the troublesome harmonics which exceed specifications.

Frequently, facility personnel discover either accidentally or by power line disturbance monitoring that a UPS system is called for but they may have no expertise in specifying the system. If they have any reservations about their ability to specify and procure a UPS which will solve their power problems, they would be well advised to retain a competent consultant having expertise in this field. More often than not, an expert consultant can save the facility more than enough money to pay his fee while ensuring a satisfactory installation and solution to the problem. The UPS field is still really in its embryonic stage, so experts are few and far between. Make certain that the consultant you choose has experience in the field.

It is easy to see from the examples cited that low efficiency, or, more appropriately, *inefficiency* is one of the worst enemies of energy conservation. Not only does the wasted energy dissipate in heat to our environment, and it robs everyone of financial resources. Unknown are all the intangible deteriorating effects on equipment life and performance. Unknown are many factors caused directly or indirectly by inefficiency. Today, UPS efficiency is taking on its new important role in the specifying of systems. It is as it should be. ■



## Everything in Fail-Proof Digital Printers.



Used by the world's leaders including Anadex, Digitec, Doric, Esterline, etc.

Whatever your hard-copy need—alpha-numeric/digital printout; multi-copy; multi-color; ordinary calculator paper/pressure-sensitive tape; card, label, fan-folded forms, sales slip,—one of our 12 basic field-proven impact printers will suit you perfectly.

Products of Shinshu-Seiki, world-famous for a decade of reliability. Choose up to 21 columns, up to 42 characters/column, 3.4 lines/sec printing speed. Lowest sample prices. Phone Floyd Makstein, VP/Marketing or write . . .



**C. Itoh Electronics, inc.**  
SYSTEMS & COMPONENTS DIVISION  
280 Park Avenue, New York, NY 10017  
(212) 573-9466. Telex: WUD 12-5059

CIRCLE NO. 21 ON INQUIRY CARD

# product focus

BARBARA A. REYNOLDS / Associate Editor

## H-P'S NEW 3000 FAMILY

Hewlett-Packard's 3000 Series II machines are a new *family* — there's more than one. But they're not entirely unrelated to the 3000 CX family. The earlier 3000 architecture has been retained as has the I/O hardware so 3000 Series IIs are program compatible with other 3000s. The difference is *throughput* — H-P claims two to six times that of the 3000. The Series II CPU is faster; many functions formerly performed by software have been micro-programmed; and the 18-pin 4K RAMs H-P just released for its 21MX are used instead of core for a 33 percent increase in memory speed. There's also a new operating system and larger instruction set (209). A fault control system detects and corrects errors without affecting processing speed and an automatic error logging system logs each error and the part causing it.

The new family spans the market from super minis to small-scale general purpose computers (IBM territory). With the interactive data base management software, IMAGE/QUERY, the 3000 Series II is oriented toward online distributed processing types of applications, either business or scientific. RPG II, Cobol, Basic, Fortran and SPL (H-P's System Programming Language) are all available.

Model 5 of the Series II is in the "super mini" market with a base price of \$110,000. That includes 128K bytes



H-P's SUPER MINI — The Model 5 competes with Digital's 11/70 or Data General's Eclipse.

of MOS memory (expandable to 256K), a 15-megabyte disk, 1600-bpi tape, 2640 CRT, operating system, utilities and SPL. Up to 31 terminals, four line printers, eight 47 MB disks and three 15 MB disks can be added.

Model 7 at \$150,000 is an upgrade for small business computer users. It has a larger standard disk capacity than the Model 5 (two 47 MB drives) and more software (Cobol, RPG II and

IMAGE/QUERY). Top of the line and H-P's largest ever is the Model 9 with MOS memory of 320K bytes (expandable to 512K) and the same peripheral and software complement as the Model 7. Further expansion can include up to seven additional tape drives, four line printers, 340 MB disk capacity and 63 terminals. With a purchase price of \$190,000, the Model 9 is in the lower end of IBM's general purpose market (370/115, 125). Both companies are

oriented toward extensive customer support, but H-P's systems are more transaction oriented than IBM's which tend to be batch.

H-P is going back to its old philosophy of announcing a product only when it's been extensively tested and is ready to ship so customer deliveries will start in June. The 3000 Series II replaces the 3000 CX family, but those customers can convert to a 256K Model 9 for \$75,000.

# Strike it rich with Roytype's new gold computer ribbons.

When it comes to fill-in letter writing and scanning, Roytype Gold Scanoptik™ computer ribbons can't be beat. Their write is jet black, clear, nonsmearing, character after character.

They'll save you money two ways. First, you'll get up to one million lines per ribbon. Second, the writing quality of Gold Scanoptik ribbons is so good that major utilities and other commercial customers have reported rejection rates as low as 1/2 of 1%.

Gold Scanoptik ribbons are work savers, too. They incorporate a special cohesive ink formulation that doesn't "dust" on impact. Downtime and maintenance are held to a minimum.

Your Roytype salesman can tell you about Gold Scanoptik or other multipass film ribbons for computers, typewriters and accounting machines. Give him a call or mail the coupon.

For more information contact your Roytype representative, or write J. T. Dessureau, Roytype Division of Litton Industries, 1031 New Britain Avenue, West Hartford, CT 06110.



**ROYTYPE**

Impression and Imaging Products

CIRCLE NO. 22 ON INQUIRY CARD

## INTEL SPINOFF ZILOG

Another spinoff, so what else is new? Exxon Enterprises and Frederico Faggin make this new. Faggin left Intel two years ago, taking Ralph Ungermann and Matoshi Shima with him. Zilog was the result. All three men were integral parts of Intel chip development — Faggin was responsible for Intel's MCS-4, Ungermann for the 4040 microcomputer set, and Shima for the 8080 CPU. But the company's base didn't stop with engineering minds. Exxon Enterprises decided it was worth backing. And Mostek recently decided it was wise to join in Zilog's product development.

Zilog is proclaiming its first product as a third-generation LSI component set, as opposed to Intel's second generation 8080A. The initial Z-80 product line includes a CPU, four I/O circuits and a floppy-based hardware/software development system. Although the N-channel CPU is software compatible with the 8080A, Zilog considers it third generation for these reasons. The 158-instruction set includes all of Intel's 78

instructions plus new instructions for four, eight and 16-bit operations. There are 17 internal registers, including two index registers (more than twice the number of the 8080A). These features combined with three modes of fast interrupt response and a nonmaskable interrupt give the Z-80 throughput far above the 8080A. Additionally, the Z-80 can generate all control signals for standard memory circuits. So static RAMs can be interfaced using only an external address decoder and dynamic RAMs can be interfaced without external logic.

The Z-80 Parallel I/O (PIO) circuit that interfaces most printers and card readers includes two independent ports, each with eight I/O lines and two handshake lines programmed by the CPU. The Serial I/O (SIO) circuit is also programmable and is similar in design to the PIO except that it handles serial devices such as floppies, CRTs and communication devices. The Counter Timer Circuit contains four clocks, each with its own nested priority interrupt control. Although with the Z-80's fast interrupt response time, a DMA is not needed for most applications, Zilog

provides a DMA circuit for larger, high-speed applications.

Custom versions of the Z-80 have already been shipped. However, volume production shipments haven't begun yet and pricing is still on a customer by customer basis.

## NEC TAKES ON THE GIANT

In its bid for a firm footing in the semiconductor market, NEC Microcomputers (Lexington, MA) has announced 19 — yes, nineteen — eight-bit microcomputer products. There's two N-channel 8080A CPUs, eight support chips, seven memory chips and two controllers.

Both new processors are faster than NEC's standard 8080A processor that has a 2-MHZ clock frequency. The  $\mu$ PD8080A-2 has a 2.5-MHZ clock frequency and is priced at \$27.30 in quantities of 100. The 3-MHZ  $\mu$ PD8080A-1 is priced at \$35 in quantities of 100. NEC also has a 1.25 MHz processor. All processors have Intel's standard 79-instruction set.

In the memory field, NEC has three new families of NMOS RAMs, a CMOS RAM and an electrically erasable PROM (EEPROM). The 16-pin, 18-pin and 22-pin families of NMOS static RAMs all have access times of either 250, 350 or 450 nanoseconds. The 16-pin RAM is organized 1024 x 1; the 18-pin and 22-pin RAMs are organized as 256 x 4.

The low power CMOS device is organized 256 x 4 and has an access time of 1000 nsec. All inputs and outputs are directly TTL compatible. NEC's new EEPROM —  $\mu$ PD458D — has a 1K word x eight-bit capacity. That makes it four times larger than NEC's other EEPROM — the  $\mu$ PD454D. Both are N-channel devices fast enough to be used with 2-MHZ processors. Maximum access time of the 454 is 800 nsec; for the 458, it's 450 nsec.

NEC's new products also include a fast programmable universal asynchronous receiver-transmitter (UART) that uses NMOS technology. The UART is externally programmable to control word length, baud rate to 50K, odd/even parity generation and data word format. Closing out the introduction are an eight-bit I/O port and a bidirectional four-bit bus driver, both compatible with Intel products. All new products will be available in the next few months.

*The results of the fifth annual market survey among buyers of minicomputers, microprocessors and miniperipherals are now available in a special 80-page report.*

*See ad on pages 58 and 59.*

## UNINTERRUPTIBLE POWER SYSTEMS

FROM 700 VA TO 37.5 KVA

- Single Phase & Three Phase
- On Line Systems
- Minimum MTTR
- Maximum MTBF
- Seismic IE Qualified

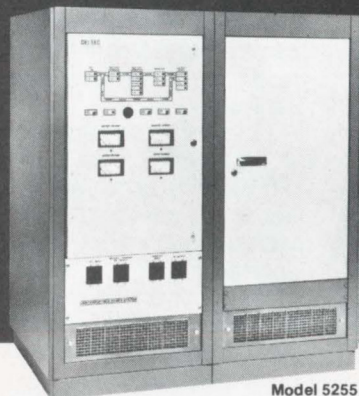

Model 5255  
15 KVA



Model DSU-710  
700 VA

**WRITE FOR FREE POWER SELECTION GUIDE.** Deltec has compiled detailed data to assist you in specifying a standard reliable system to meet your application. Installation requirements, including suggestions as to possible methods of maintaining maximum MTBF and MTTR at the most economical price, are also included.

Deltec's standard Uninterruptible Power Systems solve numerous types of power problems — blackouts, brownouts, transients — that cause expensive down time on critical electronic and computer systems. Our on-line power equipment is available as standard single systems and as partially or totally redundant component systems. Options include an electronic transfer switch for ultimate reliability and load sharing between redundant systems for no break power, and complete monitoring and control systems for remote indication or other computer control.

Deltec enjoys a growing reputation for producing advanced-designed power conversion systems which meet specific customer requirements. Our equipment is engineered with the users' requirement in mind and that means ease of installation and maintainability by your own local electricians with complete factory support.

### DELTEC

CORPORATION

980 Buenos Avenue • San Diego, CA 92110  
(714) 275-1331 • TWX 910 335 1241

CIRCLE NO. 23 ON INQUIRY CARD

# An affordable solution in your battle to cost-justify a minicomputer.

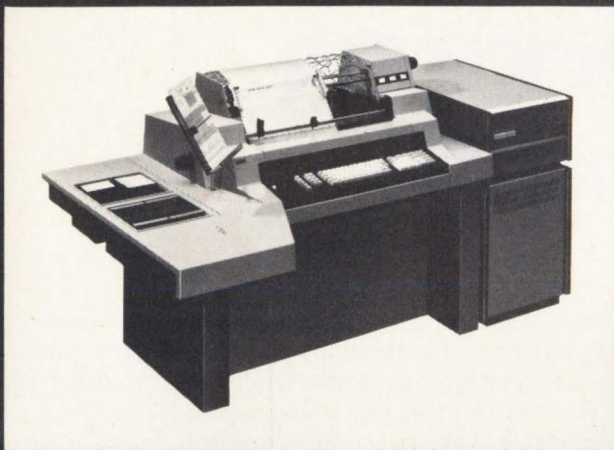

The "Affordable NCR 499" gives small businesses the kinds of processing advantages previously enjoyed only by companies with larger EDP systems. Yet it costs a lot less than you might imagine—even for a minicomputer.

The secret? The 499 combines several new technological features with an exceptionally wide assortment of ready-to-go application programs. The result is that now almost any type of small operation—commercial, industrial, medical, government, education, financial or retail—can cost-justify high-volume processing for your specific requirements.

Check out "The Affordable 499" for yourself. Phone the NCR office in your area. Or write to NCR Corporation, Box 606, Dayton, Ohio 45401. Ask for our free brochure that describes the advanced NCR 499 minicomputer.

**NCR**  
Complete Computer Systems



CIRCLE NO. 27 ON INQUIRY CARD

# SYSTEMS-ON-A-CHIP

PART - 2

## MICROPROCESSOR SCORECARD

### EDITOR'S NOTE:

In May we began our two-part technology profile on "Systems on a Chip" with a review of the extraordinary developments in the semiconductor and microsystems industry over the year and a half since we presented our first full-scale profile on microprocessors and microcomputers. We also presented a review of microprocessor principles, a cautionary note ("Beware the Microprocessor") on the difficulty of applying the microprocessor in real-life systems, and some new ideas for peripherals suited to the microworld.

This month we conclude our profile with an updated survey of available microprocessors, a new "Microprocessor Scorecard" from MicroComputer Technique, Inc., and a discussion and survey of the other chips which are necessary to applying the capabilities of the microprocessor in the real world.

Barely two years ago the microprocessor was a limited, slow device available from very few manufacturers and denigrated by many systems engineers for its awkwardness, limited instruction set, and very low speed. There were those who believed that the microprocessor would never become a serious challenger to the high-speed minicomputer.

Last year, the microprocessor had become sufficiently improved in performance and sufficiently more widespread in sourcing, that this publication devoted two full issues to describing the available microprocessors, the microcomputers that were made from them, the methods of programming, input-output problems, etc. Now, only a year later, this swiftly-maturing industry has presented us with complete families of chips which in combination, usually on a single board, make a processor more powerful than even most of the believers thought possible two years ago.

There are several phenomena operating in parallel to produce this result. Most obvious, of course, is the improvement in capability, availability and reliability of the microprocessor itself. However a microcomputer does not live by the microprocessor alone, and the other functions which were considered subunits of a general purpose computer, are also being condensed into single chips, or in some cases a few chips.

The microcomputer revolution, therefore, springs not from the microprocessor alone, but from a variety of "systems on chips"; memory, modems, I/O, A/D, etc.

Another manifestation of the maturity of the microcomputer industry is the availability of a large number of microcomputer development systems. We discussed at some length last year the fact that one of the most difficult aspects of implementing a microprocessor-controlled system, or microcomputer, is the development and debugging of the programs to be executed by the microprocessor. This is true because the small microprocessor systems do not contain the necessary storage space, and are usually not affixed

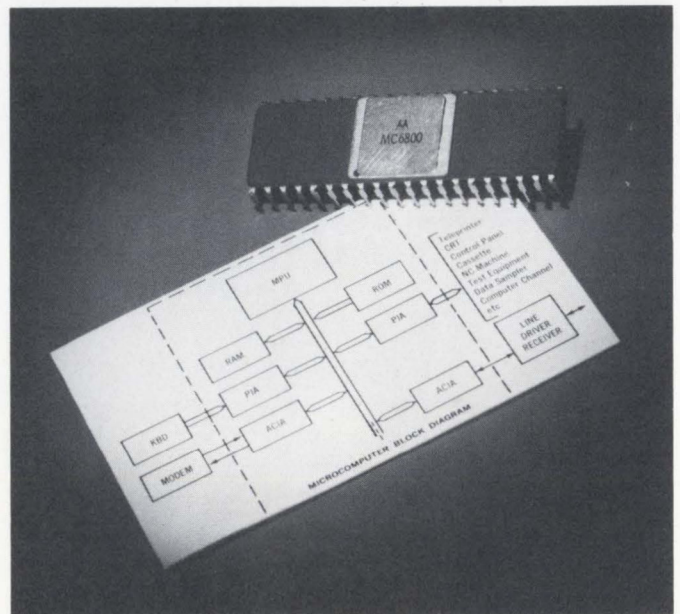

Motorola's MC6800 microprocessor and its functional block diagram.

with the necessary peripherals, to debug programs, because they are usually used in more limited environments than the larger computers. This is becoming somewhat less so as microcomputers increasingly encroach upon the domain of the minicomputer.

Given the progress in the development of subsystems in addition to the microprocessor on chips, a significant aspect of recent product introductions is the profusion of the single board microcomputer, which, on one printed circuit board, provides processor, memory, input-output control, and timing circuitry.

## MEMORY CHIPS

Memory on a chip comes in many forms, several of which are direct replacements for subunits commonly used in computer processors. Random access memory, or RAM, is the direct functional equivalent of the core memories which have been the mainstay of computer storage for two decades. Semiconductor RAM, of course, is now common not only as the memory on a chip for microprocessor systems, but in direct replacement of core memories for even the largest computer processors.

A portion of the core memory for a conventional computer has always been devoted to storage of the program which the computer is to execute. In the early 1960s, another form of storage, the read-only-memory, was introduced. It has variously been known as firmware and micro-programming, and has also been variously used to store portions of a machine program which are not subject to change (e.g., the multiply-divide algorithm), and to perform functions which could have been done by wired-in logic circuitry.

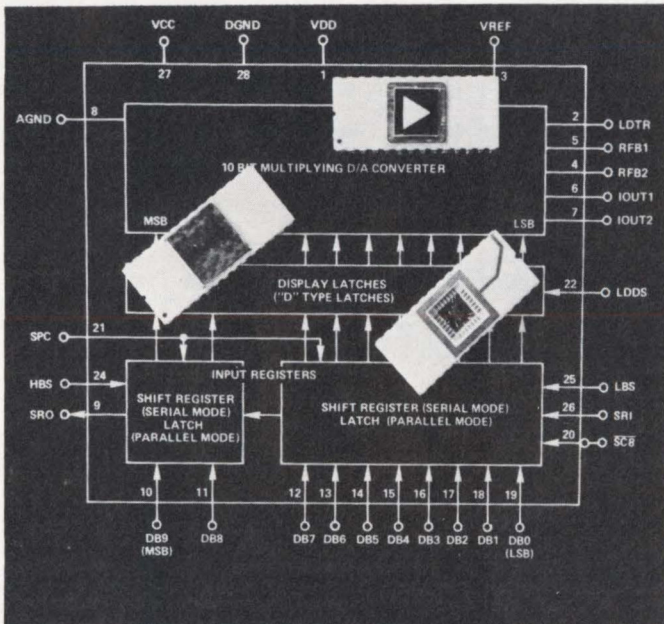

Analog Devices directly-interfaceable buffered D/A converter.

The read-only-memory, ROM, is the system on a chip which performs this function for the microcomputer; it also has been utilized in minicomputers and larger computers, but it is not common to the very large machines. The ROM is used in a microcomputer for controlling functions of the machine, i.e., defining the instructions which will be executed, and therefore the characteristics of a machine can be appreciably altered by inserting a different ROM. There are, in fact, computers which can emulate any of several other computers, by changing the content of their ROM memory.

ROMs and RAMs are made using the same semiconductor technology which has brought us integrated circuits and the microprocessor; in point of fact, the techniques which ultimately led to the microprocessor evolved largely from research which was being conducted to create more capacious memories. There are also variations on ROMs and RAMs, such as EROMs and PROMs, in which information stored in the ROM can be altered under special electrical or optical conditions; the normal, or mask-programmed ROM has its information permanently implanted when it is manufactured, and the information can never be altered. Memory chips and their sources were thoroughly discussed in our Tech-

PATCHES • SPLICERS • ENCODERS

**NOW!**  
For Teletype and Reels

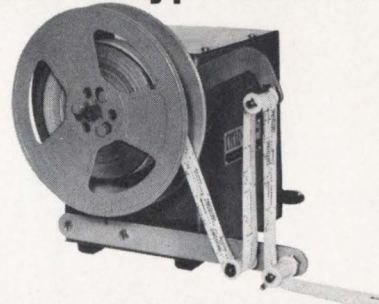

## Automatic Heavy Duty Perforated Tape Winders and Tape Feeders

Especially designed for teletypewriters and similar applications, the Robins Series 200 Winders and Feeders accommodate standard 1/2" ID hub reels up to 10 1/2" diameter and 1" width. Speeds range from 15 to 350 codes per second on a 4 1/2" NAB core. A sensitive torque response switch lever matches the feed or take up of the feeder and winder to the requirements of the master system.

Write for full line catalog. Dealer inquiries invited.  
(516) 543-5200

**ROBINS**

ROBINS INDUSTRIES CORP. data products division  
75 Austin Blvd., Commack, N.Y. 11725

WINDERS • FEEDERS • SYSTEMS

CIRCLE NO. 25 ON INQUIRY CARD

**FREE  
TIC TAC TOE  
PROGRAM  
FOR S/32**

Send for a free game program  
for your IBM System 32, courtesy  
your local Tab representative.

**TAB**  
PRODUCTS CO  
2690 Hanover Street, Palo Alto,  
California 94304.

Name \_\_\_\_\_  
Company \_\_\_\_\_  
Address \_\_\_\_\_  
City \_\_\_\_\_ State \_\_\_\_\_ Zip \_\_\_\_\_  
System/32 installation date \_\_\_\_\_

CIRCLE NO. 24 ON INQUIRY CARD

# MICROPROCESSOR

TABLE 1 —  
MICROPROCESSOR  
SCORECARD

	CLASSIFICATION	TECHNOLOGY	PARTS FAMILY										FEATURES			
			CLOCK DRIVER	I/O Interface	UART/USRT	RAM	ROM/PROM	Interface	Interrupts	One-chip CPU	Microprogrammed	Accessible Stack	DMA Ability	BCD Arithmetic	<0, >70° C. Avail.	WORD SIZE (Data/Instruction)
AMD 2900	4-bit Slice	TTL	●		●	●	●				●		●		4N/9	
DATA GENERAL mN601	16-bit CPU	NMOS	●		●		●						●		16/16	32K
ELECTRONIC ARRAYS 9002	8-bit CPU															
ESSEX SX200	4-bit CPU	PMOS	●							●			●		4/8	1K
FAIRCHILD F8	8-bit CPU	NMOS	●	●	●	●	●	●	●	●		●	●	●	8/8	64K
FAIRCHILD MACROLOGIC	4-bit Slice	TTL			●	●	●			●					4N/6	
GENERAL INSTRUMENTS CP-1600	16-bit CPU	NMOS		●	●	●	●		●	●	●	●			8/8	64K
INTEL 3000	2-bit Slice	TTL				●	●	●	●		●		●		2N/18+	512
INTEL 4004	4-bit CPU	PMOS	●	●		●	●	●		●			●	●	4/8	4K
INTEL 4040	4-bit CPU	PMOS	●	●		●	●	●	●	●			●		4/8	8K
INTEL 8008-1	8-bit CPU	PMOS	●	●	●	●	●	●	●	●				●	8/8	16K
INTEL 8080A-1	8-bit CPU	NMOS	●	●	●	●	●	●	●	●		●	●	●	8/8	64K
INTERSIL 6100	12-bit CPU	CMOS	●			●			●	●			●		12/12	4K
MONOLITHIC MEMORIES 6701	4-bit Slice	TTL				●	●			●			●		4/17	
MOS TECHNOLOGY 6502A	8-bit CPU	NMOS	●	●		●	●	●	●	●		●	●		8/8	64K
MOSTEK 5065	8-bit CPU	PMOS				●	●		●	●		●	●		8/8	32K
MOTOROLA 6800	8-bit CPU	NMOS		●	●	●	●		●	●		●	●	●	8/8	64K
MOTOROLA 10800	4-bit Slice	ECL		●		●	●	●		●			●		4N/16	
NATIONAL SC/MP	8-bit CPU		●	●		●	●		●	●		●	●		8/8	64K
NATIONAL GPC/P	4-bit Slice	PMOS								●	●	●			4N/23	100
NATIONAL IMP-4	4-bit CPU	PMOS				●	●	●	●	●			●		4/4	4096
NATIONAL IMP-8	8-bit CPU	PMOS				●	●		●	●	●				8/8	64K
NATIONAL IMP-16	16-bit CPU	PMOS				●	●		●	●	●				16/16	64K
NATIONAL PACE	16-bit CPU	PMOS	●	●		●	●	●	●	●	●	●	●		16/16	64K
NATIONAL TCS	4-bit CPU	PMOS	●	●		●	●		●	●			●		4/8	8K
NEC μCOM-8	8-bit CPU	NMOS		●	●	●	●	●	●	●		●	●	●	8/8	64K
RCA COSMAC	8-bit CPU	CMOS	●			●			●	●		●	●	●	8/8	64K
ROCKWELL PPS-4	4-bit CPU	PMOS	●	●	●	●	●		●	●			●		4/8	8K
ROCKWELL PPS-4/1	4-bit CPU															
ROCKWELL PPS-8	8-bit CPU	PMOS	●	●	●	●	●		●	●		●	●	●	8/8	16K
SIGNETICS 2650	8-bit CPU	NMOS				●	●		●	●		●	●		8/8	32K
TEXAS INSTRUMENTS SBP0400	4-bit Slice	IIL				●	●			●			●		4N/9+	
TEXAS INSTRUMENTS TMS1000	4-bit CPU	PMOS							●	●			●		4/8	2K
TEXAS INSTRUMENTS TMS9900	16-bit CPU	NMOS		●	●	●	●	●	●	●		●	●		16/16	32K
TOSHIBA TLCS-12	12-bit CPU	NMOS		●		●	●		●	●					12/12	4K
TRANSITRON 1601	4-bit Slice	TTL							●	●	●				16/16	32K
WESTERN DIGITAL 1600	16-bit CPU	NMOS			●	●	●		●	●	●				16/16	64K
ZILOG Z-80	8-bit CPU	NMOS		●	●				●	●	●	●	●		8/8	64K

# SCORECARD®

CLOCK (kHz/Phases)	REGISTER ADD TIME ( $\mu$ sec per Data Word)	NUMBER OF CPU REGISTERS			RETURN-STACK SIZE (Nr x Bits)	VOLTAGES REQUIRED	POWER DISSIPATION	PACKAGE SIZES (DIP Pins)	STATUS		REMARKS
		ALU	XR	GP					First Samples	First Deliveries	
8300/1	.12	1		17	5	.9	16,20,24,40	3Q75	4Q75	Second Source: Motorola	
	2.4	1		4	(RAM)		40	3Q76	4Q76		
500/0	16	1		64	1x10	10 ~ 18	.15	28		Clock, Ram, ROM on Chip	
2000/0	2	65			(RAM)	+5,+12	.6	40	1Q75	2Q75	Second Source: Mostek
13333/1	.075	8				5	.5	14,18,24	3Q75	1Q76	
5000/2	2.4	6			(RAM)	-3,+5,+12	.6	40	3Q75	3Q75	
6061/1	.165	2		10	(None)	5	.8	28,40	3Q74	3Q74	Second Source: Signetics
740/2	10.8	1		16	3x12	15 or (-10,+5)	1.0	16	2Q71	4Q71	Second Source: National
740/2	10.8	1		24	7x12	15 or (-10,+5)	1.0	16,24	4Q74	4Q74	
800/2	12.5	1		6	7x14	-9,+5	1.0	18	4Q71	1Q72	
3000/2	1.33	1		6	(RAM)	-5,+5,+12	1.0	40	4Q73	2Q74	Second Source: AMD, T.I.
4000/0	5	1		1	Modifies Program	5	.01	28,40	2Q75	3Q75	PDP-8 Code
6666/1	.2	3		16	(None)	5	1.0	40	1Q74	2Q74	
2000/0	1	1	2		(RAM)	5	.25	40	3Q75	4Q75	Second Source: Synertek
1400/3	10	3			(RAM)	-12,-5,+5	.7	40	1Q74	3Q74	
1000/2	2	2	1		(RAM)	5	.25	24,40	2Q74	4Q74	Second Source: AMI
	.055	1				-5.2,-2	1.3	48	3Q76	3Q76	
1000/0	38	1	3	1	(None)	12 or (-7,+5)	.9	40	4Q75	1Q76	
715/4	1.4	8			16x4N	-12,+5	.7	22,24	1Q73	3Q73	$1 \leq N \leq 6$
500/4	12	4			7x12	-12,+5	1.0	24,40	3Q74	4Q74	
715/4	4.6	3	1		16x8	-12,+5	1.0	22,24	4Q73	1Q74	
715/4	4.6	2	2		16x16	-12,+5	1.2	22,24	1Q73	3Q73	
2000/2	8	2	2		10x16	-12,+5,+8	.7	40	1Q75	2Q75	
400/1	10	1		161	2x11						
2000/2	2	1		6	(RAM)	-5,+5,+12	.8	42	4Q74	2Q75	
		1		p	rx16	5 ~ 12	.01	40	1Q76	2Q76	$(p + 2r) \leq 30$
200/2	5	1		1	2x12	17	.225	42	1Q72	3Q72	
256/2	4	1	1	2	(RAM)	17	.3	42	4Q74	1Q75	
1200/1	4.8	7			8x15	5	.5	40	1Q75	2Q75	
1000/1	1	10				>.85	.13	40	4Q74	3Q75	
500/1	12	1		1	1x6	15	.1	28,40	1Q75	2Q75	Clock, RAM, ROM on Chip
					(RAM)			64	1Q76	2Q76	
1000/3	13	4		6	(RAM)	-5,+5	.8	16,24,26,42	2Q74	3Q74	
	.4	u	v		(RAM)			40	2Q76	3Q76	$(u + v) \leq 8$
3300/4	.6	x	y		(RAM)	-5,+5,+12	1.2	40	3Q75	3Q75	$(x + y) \approx 16$
2500/1	1.6	1	2	13	(RAM)	5	1.0	40	1Q76	2Q76	8080A Compatible

# UNDERSTANDING SDLC

A 12-page reprint collects and *updates* the series of five articles on IBM's Synchronous Data Link Control (SDLC) line protocol which appeared in MODERN DATA between February and September, 1975. *Not included in the published series but contained in the reprint* are several pages on the derivations of the equations used in the articles. Taken together, the series provides a comprehensive, independent explanation and appraisal of this most important line protocol, *written in the working language of computer-communications users*. SDLC subjects covered include:

1. General Concepts and Structure
2. The Control Field
3. Supervisory and Non-Sequenced Control Field Formats
4. Throughput Calculations
5. An Analysis of Response Time Performance
6. Derivations of Equations Used.

**PRICE — \$2.95**

Use handy coupon below — only pre-paid orders accepted.

**PRE-PAID  
ORDERS ONLY**

**MINI-MICRO SYSTEMS REPRINT DEPT.**

5 Kane Industrial Drive  
Hudson, MA 01749

Enclosed is my check for \_\_\_\_\_ for \_\_\_\_\_ copy(ies) of  
"Understanding SDLC" at \$2.95 per copy.

Send reprint to:

Name \_\_\_\_\_  
Company \_\_\_\_\_  
Address \_\_\_\_\_  
City \_\_\_\_\_  
State \_\_\_\_\_

nology Profile and Product Update on semiconductor and core memories, August-September 1975.

Research into other areas of memory promise to produce replacements-on-a-chip for some of the other elements of a computer system, somewhat further from the central processor. Bubble memories, which are comprised of magnetic domains moving within a thin film, are presently laboratory items which are touted to be capable of ultimately achieving densities of 10 million bits per square inch. Closer to reality is the charge coupled device, a high speed, high density semiconductor shift register. Both of these techniques may well bid to replace magnetic surface storage devices, such as magnetic drums and magnetic disks, and in fact Intel is presently actively marketing a CCD serial memory as a replacement for small drum memories.

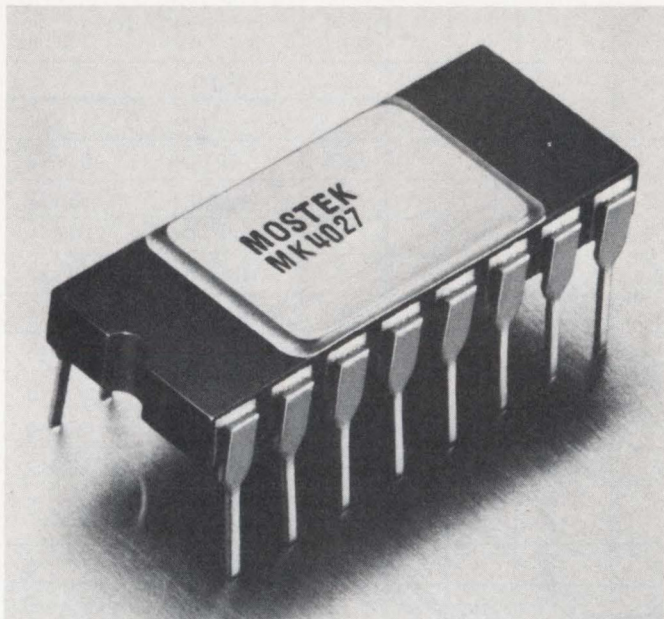

*Mostek's 4K, 200-nsec RAM.*

There is no question that the future for memories is more, faster, cheaper: more bits on single chips, operating at higher speeds, at consequent lower dollars per bit. There is also no question that as this more-faster-cheaper syndrome continues, semiconductor memories, and their cousins the CCDs and bubbles, will encroach more and more into the traditional enclaves of core and magnetic surface, and ultimately displace both of these older technologies. We have observed many times over the past decade that magnetic tape is a dying technology; magnetic disks and drums may be the dying technology of the next decade.

## MODEMS ON A CHIP

In our Technology Profile on Data Communications, April 1975, we noted that modems on a chip were beginning to appear as a natural part of the microcomputer revolution. The chips described in that article last year, in general needed external circuitry to make them work, and we noted that they were not suited for direct use by users. Four manufacturers — Sermatec, Exar-Integrated Systems Inc., Motorola, and Rockwell — offered the only products available at that time.

Motorola includes its modem in the series of chips compatible with its MC6800 microprocessor, and provides a fully compatible modem on a chip. Using this chip, systems engineers can directly include communications capability in their microcomputers.

## TABLE 2 — REFERENCE LITERATURE

For more information on the microprocessors described in the Scorecard, circle the appropriate reader inquiry number on the inquiry card opposite the back cover.

COMPANY	READER INQUIRY NO.
AMD, Sunnyvale, CA . . . . .	96
Data General, Southboro, MA . . . . .	97
Electronic Arrays, Mountain View, CA . . . . .	98
Essex, Pittsburgh, PA . . . . .	99
Fairchild, Mountain View, CA . . . . .	100
General Instruments, Hicksville, NY . . . . .	101
Intel, Santa Clara, CA . . . . .	102
Intersil, Cupertino, CA . . . . .	103
Monolithic Memories, Sunnyvale, CA . . . . .	104
MOS Technology, Norristown, PA . . . . .	105
Mostek, Carrollton, TX . . . . .	106
Motorola, Phoenix, AZ . . . . .	107
National Semiconductor, Santa Clara, CA . . . . .	108
NEC, Lexington, MA . . . . .	109
RCA, Somerville, NJ . . . . .	110
Rockwell, Anaheim, CA . . . . .	111
Signetix, Sunnyvale, CA . . . . .	112
Texas Instruments, Dallas, TX . . . . .	113
Toshiba, Kanagawa, Japan . . . . .	114
Transitron, Wakefield, MA . . . . .	115
Western Digital, Newport Beach, CA . . . . .	116
Zilog, Los Altos, CA . . . . .	117

Western Digital Corporation has joined the modem-on-a-chip vendors with several models of transmitters-receivers on a chip, including full or half duplex operation, both synchronous and asynchronous, and all of the conventional goodies one expects in a modem.

One might expect that the introduction of modems on a chip would greatly threaten the established manufacturers of data modems. Such is the case for those modem manufacturers who offer elementary, board-level, modems which are commonly incorporated by systems engineers into other systems such as terminals and communications processors. It still, however, requires the abilities of an engineer to assemble a microcomputer from the sets of chips offered by the semiconductor manufacturers, and the user must continue to buy his modems in fully packaged and engineered form, even as he must continue to buy his computer fully packaged, regardless of whether it is a minicomputer or a microcomputer.

Codex has incorporated the modem on a chip into its own well established line of data modems, and now offers these packaged units to the user. From the user's point of view, it should make no difference whether his packaged modem is comprised of discrete components, or an LSI modem, or, for that matter, vacuum tubes. To the makers of digital systems, however, the price of including a modem in his system has just been reduced from several hundred dollars to several dozens of dollars.

### OTHER CHIPS

System designers have and available for years, single chips which provided adders, subtractors, shift-registers, and other functions just shy of comprising complete subsystems. A logical next step up from these logic elements was the pro-

grammable logic array, PLA. The PLA contains the logic circuitry necessary to perform common logic functions, simple arithmetic operations, bit manipulations, etc. When combined with a read only memory which contains the sequence of events to be executed by the PLA, a processor of the level of a dumb sequential controller can be cheaply provided, and this is a more economical solution to many problems than the more glamorous microprocessor. This concept was known long ago when read only memories were used to control arrays of discrete logic; the read only memories in the earliest units were mechanical drums with microswitch sensors.

Having provided the processor-on-a-chip, and the memory-on-a-chip, and the modem-on-a-chip, the next most pressing problem in creating a microcomputer is the input-output function and the control of peripheral devices. Motorola provides its MC6820 peripheral interface adapter, PIA, which interfaces its microprocessor to peripherals through two 8-bit bidirectional data buses and 4 control lines; the PIA is contained on one chip. Rockwell provides a general purpose input-output device, GPIO, which is addressed from the microprocessor and its associated ROM, and provides for twelve inputs and twelve outputs. Also, as part of its PPS-8 microprocessor system, Rockwell has announced a single-chip floppy disk controller, which, in conjunction with other LSI circuits, will reduce the costs of floppy disk control systems from \$1000 to \$200.

There are, of course, single chips available which provide a complete watch circuit, calculator, etc., and it may well be that some of these chips will ultimately be used to provide now-unknown features in microcomputer systems.

## THE EUROPEAN MINICOMPUTER PERIPHERALS AND SOFTWARE MARKET

The value of minicomputer peripheral and terminal equipment shipped in Europe in 1974 was \$69 million. Shipments will increase more quickly than for the minicomputer processors, rising to \$621 million by 1984 — almost nine times the current level. The cumulative market for the 1975-1984 period will total more than \$3.2 billion, and an additional \$2.7 billion of main memory modules will be delivered.

Frost & Sullivan has completed a two-volume, 472-page report forecasting the market through 1984, by product (25 products), for: hard copy peripheral units; storage peripheral devices; add-on-memory modules; terminal and data entry equipment and other types of peripheral equipment; and for third-party equipment maintenance services, systems and control software, applications software and turn-key systems. Forecasts are made for Belgium, Denmark, France, Germany, Italy, the Netherlands, Norway, Sweden, Switzerland, the United Kingdom and others.

**Price \$695.** Send your check or we will bill you. For free descriptive literature plus a detailed table of contents contact:



**FROST & SULLIVAN, INC.**  
106 Fulton Street  
New York, New York 10038  
(212) 233-1080

**RESEARCH STUDY**  
**COMMUNICATING WORD PROCESSORS**  
**and the**  
**"OFFICE OF THE FUTURE"**

- 230 pages, 33 exhibits, ten year projection of the market for communicating word processors.
- Review of current technology and products—specific keyboard/printer and keyboard/CRT equipment available, timesharing services offering word processing capabilities, audio word processing equipment.
- Analysis of relationship between communicating word processors and markets for
 

FACSIMILE	ELECTRONIC MAIL
TELEPHONE	TIMESHARING
DATA COMMUNICATIONS	POSTAL SERVICES
IN-HOUSE TELEPROCESSING	BUSINESS TRAVEL
DATA ENTRY	ENVELOPES
BUSINESS FORMS	TELEX/TWX/TELEGRAPH
PRIVATE-WIRE	COPIERS
- Analysis of CWP market by application, supplier, with review of potential applications in banking, insurance, transportation, etc.
- Expected trends and developments in markets and technologies, including expected pricing trends.
- Review of activities, market position, and possible future plans of more than thirty suppliers and potential suppliers of communicating word processors.

Published May 1976.

For free descriptive literature and detailed table of contents contact:

**INTERNATIONAL RESOURCE DEVELOPMENT INC.**  
 125 Elm Street, P.O. Box 1131  
 New Canaan, Connecticut 06840 U.S.A.  
 Phone: (203) 966-5615



CIRCLE NO. 26 ON INQUIRY CARD

**COMPLETE  
 CONSULTING  
 SERVICES**

*Processors – Peripherals – Terminals –  
 Instruments – Systems – Communications*

**FOR THE MANUFACTURER**

Market Research  
 Competitive Analysis  
 Product Planning  
 Equipment/Logic/System Design  
 Engineering and Production  
 Marketing, Sales, Service

**FOR THE USER**

Problem Analysis  
 Equipment Specification  
 Vendor Selection  
 Procurement and Installation  
 Personnel Indoctrination  
 Continuing Support

**BOWERS  
 ENGINEERING COMPANY**  
 133 Hillside Road  
 Fairfield, Connecticut 06430  
 (203) 255-1461

Intel has introduced a programmable keyboard-display unit and a programmable general purpose I/O unit for use with its microcomputer systems based on the 4004, 4040, and 8080A microprocessors, the MCS-40 and the MCS-80; these I/O control units can also be used to interface the MCS-40 and MCS-80 to each other. The programmable keyboard display unit can interface keyboards up to full teletypewriter size, and control and refresh either numeric or alphanumeric displays. The general purpose programmable I/O units provides four software configurable I/O ports (16 lines) which can operate in 14 selectable modes. Intel also offers a communications interface and a priority interrupt control unit, both single chips, for use with their microprocessors.

One of the early widespread uses of microprocessors was in instrumentation and data acquisition systems, for control of information after it was converted to digital form. However, the system-on-a-chip revolution is now beginning to

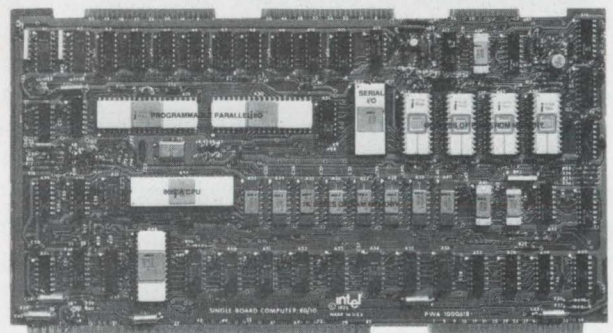

*Intel's SBC-80/10 Single-Board Computer.*

give us analog circuits for these applications as well as the more routine digital functions. Analog Devices offers 12- and 13-bit digital-to-analog converters (for \$27), and also has available single chip double-buffered digital-to-analog converters which directly interface with microprocessors to form a bus oriented I/O peripheral.

**WHITHER SYSTEMS ON A CHIP?**

There is virtually no limit as to the subunits which will ultimately be placed on the integrated circuit chip. Only economics control the potential of this technology, which more than any other is in control of the future of the computing industry – not only microprocessors and minicomputers, but the large processors as well. The controlling factor as to whether or not a function can and should be integrated onto a single chip is whether or not the function has sufficiently widespread use that it can be sold by the many thousands, at low prices, and still recover the investment necessary to have produced it in the first place.

As the technology of designing the LSI chips themselves becomes more sophisticated, and more automated, the quantities of devices that must be sold in order to make a particular function profitable will be lowered. We envision in the next decade completely automated machinery for creating LSI chips, and therefore economic viability for functions which may be salable only in the range of a few hundred.

The LSI revolution will ultimately make all of the exotic gadgetry you ever saw in Dick Tracy, Buck Rodgers, Jules Verne, Star Trek, and 2001, look as unsophisticated as the walk-in central processor on Univac II. ■



ZENTEC 9003

**IT'S SORT OF LIKE  
YOUR KID'S WAGON.**

**RUGGED.  
RELIABLE.  
FUNCTIONAL.**

**It gets the job done. Right.**

The Zentec 9003 isn't just an intelligent terminal, it's a user programmable intelligent terminal. A management system that lets you put the power where you need it... when you need it... dependably, economically, reliably.

**Complex problems. Straight answers.**

We can supply microcomputer firmware and peripherals. But that won't solve all your problems. That's why we also

make the 9003 user programmable. In other words, we play it your way.

**Before you get it, we test it.**

Maybe it doesn't make sense to tell you that you can't buy a brand new 9003. But you can't. Before we deliver your unit, we test it exhaustively. If the unit gets tired, we send you one that doesn't. That means you can plan on having your 9003 a long, long time. And as your needs expand, remember Zentec's modular peripherals.

**We know your problem.**

The answer to high line costs, Host CPU overhead or operator and management waiting time is Distributed Processing. And the answer to Distributed Processing is the Zentec 9003: A simple, rugged, dependable system. It's sort of like your kid's wagon. We think that's sort of a good idea.

**Distributed Processing From**

**ZENTEC**

**Call us for information:**

- Santa Clara (408) 246-7662 • TWX 910-338-0572
- Southern Calif. (714) 998-9680 • TWX 910-593-1339
- Midwest (312) 297-8550
- Boston (617) 879-7530 • TWX 710-380-0105

- New York (914) 949-6476 • TWX 710-568-1335
- Philadelphia (215) 688-7325 • TWX 510-668-2995
- Washington (301) 656-3061 • TWX 710-824-0093
- United Kingdom (0442) 61266 • TLX 851-825629

- West Germany 0611-634037 • TLX 841-416608
- Austria 425451 or 421675 • TLX 847-74737
- Switzerland 041-831043 • TLX 845-72231
- Netherlands 01720-94044 • TLX 844-34111

# small business computers

Buying Not Just Hardware, But Software.

Morris Carver brings a visitor into the corner of the office where his Basic/Four system sits. It's late afternoon so the two CRT's are idle and the two printers are silent. In the morning the clerks will enter the day's cash receipts, orders, and changes in inventory. The pick lists will be printed for the day's deliveries in bin sequence so the pickers can move quickly up and down the long warehouse aisles, making up packets for each dispatching area, each for one truck going to a specific geographical area.

Later the system will print invoices and ledgers. It handles salesman commissions, accounts receivable and payroll in addition to the inventory. Output reports include invoices, customer balances, inventory balances, retained commissions, monthly statements, and cash payments received daily. "What it does is unbelievable," Carver, president of Atlas Paper Co. (Woburn, MA), exclaims. He feels that the company is getting information now that they couldn't get before the system was installed — information that has helped make them a much more successful company — and he believes that Atlas Paper can live with the present system two or three more years before expanding.

His advice to a first-time computer user: Get an outside software consultant, and put him on retainer so he'll have a chance to know the company's programs intimately. That way, he'll be able to respond quickly to new requirements — much more quickly than an outsider brought in to perform an isolated task.

Sound advice, appropriate to the small business computer scene, where the single source for hardware, software, and maintenance is the exception, rather than the rule.

## WHAT IS A SMALL BUSINESS COMPUTER?

A small business computer system (SBC) can be defined as a standalone data processing system, built around a general purpose digital computer, dedicated to the processing of standard business applications — payroll, accounts receivable and payable, order entry, inventory, general ledger — that can handle inputs from mass storage devices (disk, magnetic tape, paper tape, drum) and that costs less than \$100,000 complete, including all hardware and software.



**Malcom Stiefel**, a senior systems analyst with Keystone Custodian Funds in Boston, has dealt with military command and control systems, hospital information systems, municipal information systems, and mutual fund accounting systems during his 17-year career as an independent consultant, systems engineer, systems analyst, programmer, and writer. He received a B.S.E.E. from the Polytechnic Institute of Brooklyn in 1959 and has completed graduate work at M.I.T.

This definition deliberately excludes two major types of systems: the so-called accounting computer or office computer, which can't handle the mass storage devices, and which relies instead on unit-record data storage (magnetic ledger cards, punched cards) and the data entry system, whose binary mission is to capture data on disk or tape for subsequent entry to a mainframe. The definition also obviously leaves out systems that sell for over \$100K. Granted, this limit is chosen arbitrarily, but it appears frequently in the literature as a break point separating the SBC from the not-so-SBC.

The total cost figure may be replaced by a monthly cost figure, as follows: Assume that the monthly cost of a full-payout five-year SBC lease is 2.2 percent of the price, and that maintenance cost varies (among systems) from 0.5 to 0.8 percent per month. Then the total cost will be 3 percent per month or less of the purchase price, or, looking at our upper limit, under \$3000 per month.

To relate these numbers to the sizes of businesses likely to purchase such systems, we turn to Frost & Sullivan's September, 1974 report, "Small Business Computer Market Study," which suggests that the average annual data process-



*Fig. 1 — The DEC Datasystem 310 is an online small business system that includes a PDP-8/A mini with 16K characters of core memory, a VT50H or VT52 video/terminal and a dual floppy disk unit.*

ing equipment budget of a small business is 1-1/2 percent of sales. Thus, a business doing \$2.5 million a year, with, say, 80 employees, might allocate \$36,000 per year or \$3000 per month to data processing.

The least expensive useful complete system on the market today costs around \$15,000 (including software). Such a unit would be appropriate for a company with about 12 employees and less than \$400,000 in sales. Of course, all of these figures are estimates since data processing budgets vary

from industry to industry and from company to company, as do sales per employee ratios. Nonetheless, these numbers give us a feeling for the small business computer market.

## CLASSES OF SMALL BUSINESS SYSTEMS

The two major classes of small business computer systems are: *batch systems* (Fig. 1) which tend to dominate at the upper end of the price range and *online* systems (Fig. 2) which seem to abound at the low end.

The online system, where all files are available for inquiry and updating at once, is probably most desirable in a small business environment. The management can readily keep up to date with sales, accounts payable, inventory, shipments,



Fig. 2 — Burroughs B 721 system is designed for general purpose batch data processing.

etc. Unfortunately, the online operating system (the software that assigns devices and monitors terminal activity) tends to be considerably more complex, and hence more expensive, than the batch operating system. By the same token, the online system needs enough disk space to accommodate all files at a time. These two requirements tend to escalate system costs rapidly, as the file size increases to handle a larger processing application. As a result, manufacturers would rather scale down software costs and peripheral costs in order not to price themselves out of the market at the higher end. So they turn to batch systems which can handle more work on a given hardware configuration and accept larger files (only some of which are used in a given program) for a given price.

The offsetting disadvantage of batch files, of course, lies in the relatively long turnaround times, and the relatively long delays — days, rather than minutes — that can occur in a decision-making loop as a result.

The batch system can be recognized by its card punch and reader, while the online system wears a video display terminal. Of course, as in every other segment of the data processing business, there are systems that offer both — concurrent batch and online operations in multiple partitions. The multipartition online system can be considered a subclass of the online group, rather than a separate entity. Similarly, the multipartition batch system, commonly known as a multiprogramming system, is a special kind of batch system.

But what about a *timesharing system*? How is it distinguished from an online system? Is there any difference at all? Yes, there is. In a timeshared system, each user can run his own programs independently, without regard to what any

## HOW TO USE THE TABLE

Manufacturers and the standalone small business systems they manufacture are listed in the following pages. Omitted are office computers, data entry systems and systems costing over \$100,000. In cases where specifications were unavailable from the manufacturers, reliable directories and catalogs were used as a source.

Certain columns contain mnemonic entries. For the explanation, see the appropriate footnote.

### 1. Other Peripherals:

- PTR = Paper tape reader
- PTP = Paper tape punch
- CP = Card punch
- PLT = Plotter
- OMR = Optical mark reader
- ML = Magnetic ledger card reader/recorder

### 2. Communications Lines:

- A = Asynchronous
- S = Synchronous

### 3. Modes of Operation:

- O = Online
- M = Multiprogramming; number in parenthesis corresponds to the number of partitions
- B = Batch
- T = Time sharing

other users are doing. Literally, it appears to the individual user, sitting there banging away merrily at his terminal, that he has this magnificent machine all to himself. This assumes that the operating system is smart enough to keep everyone moving so that a compute-bound job at one station isn't permitted to tie up the system, leaving everyone else sitting there for the minutes or hours it takes to finish the long job.

In a typical online system, though, the users perform

## REFERENCE LITERATURE

For further information on the systems, use the reader inquiry numbers listed below.

MANUFACTURER	READER INQUIRY NO.
Basic/Four Corp., Santa Ana, CA . . . . .	42
Basic Timesharing, Santa Ana, CA . . . . .	43
Burroughs Corp., Detroit, MI . . . . .	44
Cascade Data, Inc., Grand Rapids, MI . . . . .	45
Cincinnati Milacron, Inc., Lebanon, OH . . . . .	46
Computer Automation, Inc., Irvine, CA . . . . .	47
Data General Corp., Southboro, MA . . . . .	48
Datapoint Corp., San Antonio, TX . . . . .	49
Digital Equipment Corp., Maynard, MA . . . . .	50
General Automation, Inc., Anaheim, CA . . . . .	118
GRI Business Systems, Newton, MA . . . . .	119
Hewlett-Packard, Cupertino, CA . . . . .	120
Honeywell Information Systems, Inc., Waltham, MA . . . . .	121
International Business Machines, Corp., Atlanta, GA . . . . .	122
International Computers (USA) Ltd., New York, NY . . . . .	123
Jacquard Systems, Santa Monica, CA . . . . .	124
Litton Industries, Sweda International, Pine Brook, NJ . . . . .	195
Lockheed Electronics, Los Angeles, CA . . . . .	196
Logical Machines Corp., Burlingame, CA . . . . .	197
Microdata Corp., Irvine, CA . . . . .	198
Microfinancial Business Comp. Sys., Diamond Bar, CA . . . . .	199
Mini-Computer Systems, Elmsford, NY . . . . .	200
NCR Corp., Dayton, OH . . . . .	220
Nixdorf Computer, Chicago, IL . . . . .	221
Olivetti Corp. of America, New York, NY . . . . .	222
Qantel Corp., Hayward, CA . . . . .	223
Ultimacc Systems, Inc., Maywood, NJ . . . . .	224
Wang Laboratories, Inc., Tewksbury, MA . . . . .	225

TABLE 1 - SMALL BUSINESS SYSTEMS

MANUFACTURER Model No.	CPU		DATA ENTRY TERMINAL		CARD READER		DISK	MAG TAPE		PRINTER			
	Word Length (Bits)	Memory Capacity (Kbytes)	Type	No. of Units	Columns	Speed (cpm)	Capacity (Mbytes)	Type	No. of Units	Type	No. of Columns	Speed (lpm)	Speed (cps)
<b>BASIC/FOUR</b> Model 400	8	8-48	Video	1-4	80	400	2.1-16.8	Reel	2	Line	132	200	
Model 600	8	13-45	Video	1-8	80	400	12-48	Reel	2	Serial Line Serial	132 132	132 200	165 165
<b>BASIC TIMESHARING</b> 4000/25		64					49-392						
<b>BURROUGHS</b> B80		32-60	Video				2-27.6	Cartridge	1-4	Serial Line	150/256	160/250	160/180
B721		32-96	Video		80 96	200/ 300 300	4.6-36.8	Cartridge Reel	1-4	Line Line	132	120/132 400	85/160/25
<b>CASCADE DATA</b> Concept II	8	16-32	Video	16	80	300	5-40	Reel		Line	132	125/200 400/600	
<b>CINCINNATI MILACRON</b>	8	48-64	Video	1-8	80 96		5-40	Reel	1-4	Line		60/ 125/300/600	
<b>COMPUTER AUTOMATION</b> SyFa	16	64- 1024	Video		24		8.1-452			Serial Line		300/600	100/165
<b>DATA GENERAL</b> Eclipse C/300	16	16-256	Video Tele- printer	Up to 32		150/ 400	Up to 700	Cartridge Reel		Line Serial	80/ 136	300/ 1100 132	165
<b>DATAPOINT</b> 2200	8	4-16	Video		80	300	0.256-40	Cartridge Reel	2	Serial Serial Line	132 120 132	300/600	30/330 120/240
5500	8	24-48	Video		80	300	0.256- 200	Cartridge Reel	2	Serial Serial Line	132 120 132	300/600	30/330 120/240
<b>DEC</b> Datasytem 310	8	16-64	Video	1			0.67-12.8		1	Serial or Line	132	132	30/180
Datasytem 350	8	32-56	Video Keyboard	1-4 1-4	80	300	0.512- 160	Reel	1 or more			300	
<b>GENERAL AUTOMATION</b> DM230	16	16			80	400/ 7000	0.512-40	Reel		Line	132	300/ 600	
DM250	16	32-64	Video Tele- Printer	Up to 16	80	400/ 1000	10-40	Reel Reel		Line	132	300/ 600	
<b>GRI</b> System 99	16	16-32	Video		80/ 96	300	5.3-42.4	Reel		Serial Serial Line		80 132	120 88/120/ 165/330
										Line	136	200/300/ 480/600	
<b>HEWLETT-PACKARD</b> M230	16	16-32	Video		600	5-93		Reel	1-4	Serial Line Line	132 80	200/600 300- 1100	10/30
3000 Series II Model 5	16	128-256	Video	Up to 31			15-376	Reel	1	Line			
<b>HONEYWELL</b> Model 61/58	8	5-10	Video Tele- printer	Up to 4	80	100/ 200/ 300	4.6-92			Line Line Line	96 128 132	100 100/200 300/650	

OTHER <sup>1</sup> PERIPHERALS	COMMUNICATIONS <sup>2</sup>	PROGRAMMING LANGUAGES	MODES OF <sup>3</sup> OPERATIONS	TYPICAL PRICES			COMMENTS
				Purchase	Mo. Rental	Maintenance	
PTR, PTP PTR, PTP	A/S A/S	Business Basic Business Basic II	O/M O/M	34,900 54,400	803 1251	196 240	Other models with 1- and 8-terminal capacity. Maintenance by Sorbus. Most applications programmed by software house.
	A	Basic-X	T	56,300			User supplies data entry terminals (up to 32) and printers. Larger and smaller models available.
PTR PTP	A/S A/S	Cobol, RPG, NDL, MPL Cobol, RPG, NDL	O/M B	19,510— 150,270 62,350— 70,250	1593— 1851		Virtual memory.
PTR PTP		RPG, Assembler	O, B	29,500— 53,000		188— 301	
		RPG II	O, B				Larger and smaller models available.
	A/S	SYBOL	O/M(24)	54,000			Designed for distributed data processing.
PTR PTP	A/S	Cobol, RPG II, Basic, Fortran,	O		77,400— 159,650		Infos file management software for data base management.
	A/S A/S	Databus, Basic, RPG II, Assembler Databus, Basic, RPG II, Assembler	O, B O, B	45,000 85,000	1200 2200	250 450	Up to 14 peripherals per system.
	A/S A/S	Dibol Dibol	O or B T	12,000— 15,000 30,010			
PTR, PTP, CP, PLT PTR, PTP, CP, PLT	A/S A/S	Basic, Fortran IV, RPG II, Cobol, APL, Assembler Basic, Fortran IV, RPG II, Cobol, APL, Assembler	B T	47,650 75,000	1072		Price is estimated.
CP		RPG II, Assembler	O, B				
PTR OMR		Fortran II, IV, Algol, Assembler Cobol, RPG II, Basic, Fortran, Image/Inquiry	O, B O/M, B		50,500 110,000		System includes 16 to 40 I/O channels. Other models are available.
CP, PTR,	A/S	Minicobol, Cobol, Basic	B	66,590	1405	447	

TABLE 1 — SMALL BUSINESS SYSTEMS continued

MANUFACTURER Model No.	CPU		DATA ENTRY TERMINAL		CARD READER		DISK	MAG TAPE		PRINTER			
	Word Length (Bits)	Memory Capacity (Kbytes)	Type	No. of Units	Columns	Speed (cpm)	Capacity (Mbytes)	Type	No. of Units	Type	No. of Columns	Speed (ipm)	Speed (cps)
IBM System/32	8	16-32	Video	1			5.0-9.1			Serial			40/80
System/3 Model 8	8	16-64	Video Keyboard	Up to 12			2.45-9.8	Reel	1-4	Line	132 96/ 120/136	50/100/155 100/200/ 300	
ICL 2903	24	48-144	Video	Up to 8			10-250	Reel		Line	132	300 1100	
JACQUARD SYSTEMS J100	16	16-128	Video		1-30		0.5-320	Reel		Line	132	300	
LITTON INDUSTRIES 1300	8	8-32	Video		1		Up to 0.945	Cartridge	1-3	Serial	132		140
LOCKHEED System III	16	8-64	Video		80/96	300	5-20	Cartridge Reel		Serial Line	132 132	200/600	100
LOGICAL MACHINES Adam	8	32	Video		1		10.6			Serial Line	132 132	300	165
MICRODATA Reality	8	16-64	Video		1-32		5-200	Reel	1	Serial Line	132 136	300	165
MICROFINANCIAL EDP 100	8	8-56	Video		1		0.256- 0.512	Cartridge	2	Serial	80		110
MINI-COMPUTER SYSTEMS Micos	16	65	Video	16	80	285 300/ 600/ 1000	10-320	Reel	4	Serial Serial Line	132 80 132	300/600	165/330 100
NCR CORP. 499		12-32	Keyboard	1	80	300	9.8	Cartridge	2-4	Serial Line Line	191 191 191	300	75 173
Century 8200	16	32-128	Video	1-7	80	300	4.9-34.3	Cassette		Metric Line	132 132	55 300	
NIXDORF 8870/1	16	48-64	Video	1-4		1	10-20	Reel	Up to 2	Serial Line	132 132	300	150
OLIVETTI Audit 7/Model 90	8	8-16	Keyboard			300 20	Up to 20	Cartridge		Serial Serial	256 132 to 158		40 180
QANTEL CORP. System/900	8	4	Video	1	80	500	6-12	Reel	1	Serial Line	132 136	240/300	45/165
System/1200		4-16	Video	1-6	80	500	6-120	Reel	Up to 4	Serial Serial Line	132 132 132	700- 1800	165
ULTIMACC Disk System	16	24-65	Video	1-11			5-20	Reel	Up to 4	Line	132	135/ 300	
WANG WCS/30 (2200)	8	8-32	Video	Up to 4	80	300	1-20	Cassette Reel	Up to 3	Matrix Line Serial	112/132 132 132		120/200 300 330

common jobs, such as data entry or master file updates, at several stations, all under control of one application program, all in one partition. Separate functions, such as program development at one terminal concurrent with file updates at another, cannot occur. True, this may appear on the surface to be a fine distinction, but it has great operational

impact to a user with a lot of development work, who discovers that his programmers are quitting because they refuse to work the stick shift, when the machine is available.

Rather than worry about time sharing, the low end user should be more concerned with software that allows multi-partition operation — batch in background, online in fore-

OTHER PERIPHERALS <sup>1</sup>	COMMUNICATIONS <sup>2</sup>	PROGRAMMING LANGUAGES	MODES OF OPERATION <sup>3</sup>	TYPICAL PRICES			COMMENTS
				Purchase	Mo. Rental	Maintenance	
OMR, ML	S	RPG II Fortran IV, Cobol RPG II, Basic Assembler	O, B O/B	41,600 62,525	1082		Industry application programs supplies with system at extra cost.
CP, PTR, PTP	A/S	RPG II, Cobol, Fortran	O, B				
	A/S	Basic, Assembler	O	17,500			
		Assembler	O	25,000			
CP	A	RPG II	O/M(2)	26,240		290	
		Adam	O	39,950			
	A/S	English, Data/ Basic, Proc, TCL	T				
	A	PL/M, DRS, Basic	O	10,960			CPU is an Intel 8080 microprocessor; Application software costs \$2K to \$7K, additional.
PTR PTP OMR	A/S	Extensive Basic	O	49,900			
		Neat-AM	O	17,900			Accepts magnetic ledger cards. Application software modules priced separately.
		Cobol, Neat 3	O(7)	37,420	915		Package of six (order processing, inventory control, accounts receivable, accounts payable, payroll, general ledger) costs \$3750 plus \$185 per month.
	S	Business Basic	O				
ML, PTR, PTP, CP	A/S	PL/1 (IBM 370 cross-compiler)		O			
	A/S	QIC	O	24,900	573	190	
	A/S	QIC	O	35,500	817	250	Line printer speed depends on number of characters per line.
	A	Basic, Fortran IV	O/M(15)	74,200	1514		
PLT,	A/S	Basic	O	29,100	1000		

ground — so that files can be backed up and programs can be maintained during the day, as the Lord originally intended.

#### HARDWARE, SOFTWARE AND MAINTENANCE SERVICES

The SBC buyer in many instances will deal with one company for the equipment, another for the programs, a third

for the maintenance. Sometimes this is a fine arrangement. But if any member of such a triumvirate doesn't have an intimate relationship with the others or if they don't share information freely, the customer is bound to suffer. In this respect, the SBC doesn't measure up to larger systems, where all services are normally supplied by a single company. The

SBC user, therefore, is going to need some competent legal advice at contract signing time.

He could conceivably make a deal in which the vendor takes on the responsibility for the entire package, subcontracting tasks to the software house and the maintenance company. That may result in less finger-pointing if a question arises about the source of a system problem.

Another alternative seen in many instances: The hardware supplier also gives maintenance, but another outfit handles software. Even in this case, there may be variations in which the manufacturer furnishes the operating system, but application programs come from the independent.

There are some large manufacturers, like IBM and Digital Equipment Corporation, who provide the user with a full spectrum of services. But the user isn't always best off going with a given system simply because of the one-stop shopping if the system won't satisfy his functional requirements, or if he can get enough of a price break from a smaller vendor to justify a small risk.

The practice of separate hardware and software procurements (and separate maintenance procurement) is actually a viable, widespread arrangement. Despite the potential problems, it works, and it works well every day for thousands of small businesses. If that weren't true, the practice would disappear, but it seems to be spreading. More and more small systems are being sold on the basis of separate suppliers all the time to experienced companies as well as first-time users.

#### SOFTWARE — THE CRITICAL ELEMENT

Software, not hardware, is the pivotal element in system selection. Hardware is important, but the most elegant hard-

ware in the world will be judged a hunk of junk by the small businessman who finds his staff gets twisted in knots trying to keep files intact and accurate because the software is poorly conceived.

Software is the key, partly because the hardware manufacturers understand so well how to match a CPU and a set of peripherals to do a given job. Computation speed isn't a problem; every application is input/output bound. Pick the right peripherals and you've got it made! An easy task for the salesman. Find out how large the customer's inventory is, how many accounts he wants to maintain, how large his payroll is. Look up the configuration needed to do the job in the cookbook.

In the small business system software, the application programs, as opposed to operating systems, compilers, utilities, and the rest, are most important in an environment where the user has little, if any, inhouse programming expertise.

Most vendors have relied upon turnkey application packages produced by software houses, specialists in a given industry, to meet the challenge. IBM has reacted with its own Industry Application Programs (IAP) for the System/32, developed for the construction, wholesale food, wholesale paper and office products businesses and for hospitals and membership organizations and associations.

Such an approach is an obvious choice for the programmer-less user — as long as he can live with it. There are two problems with the method, problems shared by all software packages in the world.

First, it is highly probable that a given package won't precisely fit 100 percent of the requirements of a given business. After discovering the deficiencies, the SBC user either can correct them (i.e., bring in a consultant ) or live with

# Microprocessors and Microcomputers

## A TECHNOLOGY PROFILE

Comprised of material which appeared in the January and February, 1975, issues of this publication, this 24-page Technology Profile is the most thoughtful and comprehensive effort to date to organize and summarize the complex, confusing, and fast-moving world of micro systems. This booklet will serve, for years to come, as a primer to the newcomer and a review guide for the more experienced.

Written by practicing experts:

Scott McPhillips and Jerry Ogdin — *Microcomputer Technique*, Doug Cassell — *Control Logic*, Mike Tenner and Bill Liles — *Technology Service Corp.*, Eric Garen — *Integrated Computer Systems*, Dan Bowers — *Mini-Micro Systems*.

Price: \$3.95

Per copy, prepaid, to MINI-MICRO SYSTEMS

MINI-MICRO SYSTEMS REPRINT DEPT.  
5 Kane Industrial Drive Hudson, MA 01749

Prepaid Orders Only

Enclosed is my check for \_\_\_\_\_ copy(ies) of your 24-page Technology Profile report, "Microprocessors and Microcomputers" at \$3.95 per copy.

Name \_\_\_\_\_  
Company \_\_\_\_\_  
Address \_\_\_\_\_  
City \_\_\_\_\_ State \_\_\_\_\_ Zip Code \_\_\_\_\_

them. The extent to which a user can afford to compromise is a function of the seriousness of the discrepancies.

If, for example, a business deals with customers who are in the habit of pre-paying their invoices before goods are delivered, a standard accounts receivable package might not work, since it might not allow payments to be posted until invoices are issued. If a wholesaler uses his own inventory numbering scheme, he may not be able to switch to a different scheme imposed by software unless he's willing to make drastic changes in his operations. And change is not always good. Some manual paper flow systems are superior to automated systems.

Ideally, the software should have the flexibility to be altered by the user, perhaps by changing parameter tables, to operate in a given environment, without causing a major upset in the using organization. Unfortunately, most packages have limited flexibility; some have none.

The second problem with the pre-cooked software approach is its lack of operating efficiency, measured in terms of usage of system resources (disks, core memory) and running time. Generality is *always* achieved at the expense of efficiency. Running time optimization isn't important in many small business applications where input is entered so slowly and so infrequently that virtually any reasonable response time will be acceptable. But the problem is, if resources are used inefficiently, the user may be forced into acquiring a larger configuration than he really needs, just so he can use a certain package.

An alternative to bottled software is the one taken by Morris Carver of Atlas Paper — hire a consultant, put him on retainer, tell him what you want, and make sure he performs. A more expensive approach, but one that makes a great deal of sense. The consultant can be an individual or a firm with a good reputation in the user's industry. Many small businesses are turning in this direction, as they gradually discover the limitations of the initially supplied packages.

## TRENDS

The move toward "programmer-less" systems, where the user is given hardware and application software on Day 1, can be expected to continue since it is blessed by IBM. However, the retained consultant approach will also increase in popularity, particularly among ex-

perienced users.

Another trend already started is toward microprocessor-based systems at the low end of the price range. The systems seen so far are married to small peripherals, with limited memory capacities. But inevitably, larger systems are coming so prices will erode slightly, reflecting the difference in cost of a micro and a mini in a given configuration. But processing power (and system cost) will continue to be determined primarily by speed and capacity of peripherals, as it is now.

With the advent of the micros, look

for the introduction of parallel processing systems, in which each microprocessor in a cluster performs a single task, or controls a single terminal, sharing disk space with other micros in the system. Such a system is already under development by one company, but hasn't yet been brought to market.

Frost & Sullivan estimates that there are 500,000 small businesses in the U.S. that could use small business computers. Only 10 percent of that market (if that much) has been sold so far. Obviously, SBC's have a golden future. ■

# A lot of companies offer plug-compatible disk storage systems for minicomputers.

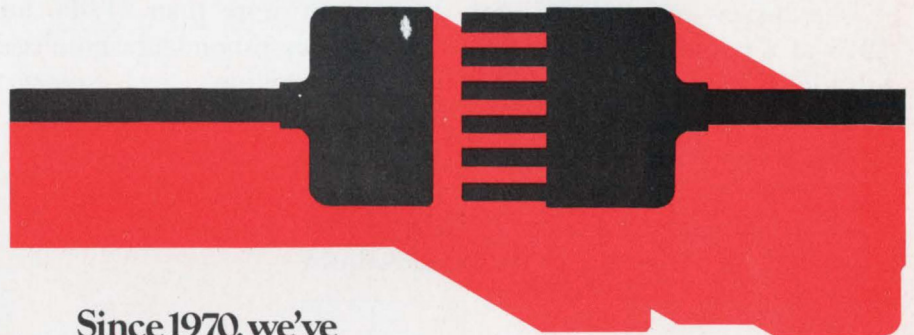

Since 1970, we've provided over 2500 customers with a lot more than the plug.

Like total software support for most popular minicomputers, especially those from DEC and Data General. Like 30-day delivery ARO. Like field-proven reliability backed by millions of hours of operation. Like super-fast access to a wide range of storage options—from 2.5 million to 1 billion bytes per system.

When you're the best, it's hard to be humble. So, if it sounds like we're tooting our horn a bit hard, it's because we think you should know about the price/performance advantages our disk systems have over those offered by the minicomputer manufacturers.

For complete technical specifications and pricing information, write or telephone us today. We'll also be happy to discuss how our disk systems are maximizing the performance of minicomputers for a growing list of Fortune-500 customers. Like IBM, Univac, Dupont, 3M Company, Western Electric, Dow Chemical, Xerox, Westinghouse, Polaroid, Eastman Kodak, TRW, CBS, CDC, DEC ...

**System Industries**  
535 Del Rey Avenue  
Sunnyvale CA 94086

SALES/SERVICE OFFICES  
Boston: Stu Oremland, (617)492-1791 New York City: Ron Caruso, (201)461-3242 Washington D.C.:  
Dave Jenoff, (703)525-3135 Cincinnati: Phil Jacobs, (513)661-9156 Los Angeles: Steve Pricer, (714)752-8904  
Sunnyvale HQ: Lynne Hodges, Dick Milligan, (408)732-1650 United Kingdom: Pip Smith, Chris Ibbott, (4862)70725

CIRCLE NO. 32 ON INQUIRY CARD

PERCENT 45 40 35 30 25 20 15 10 5 0

# announcing 1976 minicomputer- microprocessor market survey

The results of the fifth annual market survey among buyers of minicomputers, microprocessors and miniperipherals are now available in a special 80-page report.

The report features over 60 cross tabulations showing share-of-market statistics for all major vendors of minicomputers, microprocessors, microcomputers and miniperipherals.

The survey participants reported having 39,000 minis in place as of January 1, 1976 - accounting for nearly 30% of the total installed base of minicomputers in North America.

The survey respondents took delivery on more than 21,000 minicomputers in 1975 at a reported value of \$536 million. The respondents' purchase plans for 1976 include 28,000 minis at a total value of \$733 million.

Worldwide minicomputer shipments in 1976 are projected to increase by more than 30% in terms of units and dollars. This projected growth is nearly double the gain that was achieved during the economic slowdown of 1975.

## MICROPROCESSORS

Nearly one-half of the 5,700 sites represented among the survey replies reported having an active interest in microprocessors. About 8.3% of these were considering micros as substitutes for minis while 35.8% were planning to use micros as replacements for hard-wired logic or for entirely new applications.

The respondents reported plans to buy 362,000 microprocessors in 1976 and another 576,000 (up 59%) in 1977. The microprocessor vendors being considered, the distribution by application and word length, and the factors considered most important by prospective buyers of micros when choosing a vendor are tabulated and analyzed in this year's survey report.

## minicomputer shipments to survey respondents in 1975

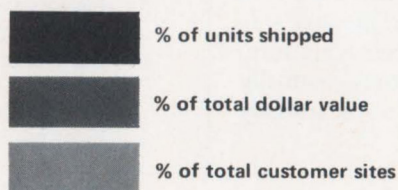

PERCENT 45 40 35 30 25 20 15 10 5 0

0 5 10 15 20 25 30 35 40 45 PERCENT



**MINIPERIPHERALS**

The survey participants reported plans to buy an unprecedented quantity and assortment of peripherals in 1976 for interconnection with their minis and micros.

Type of Peripheral	Qty to be Purchased By Survey Participants
CRT Terminals . . . . .	45,558
Card Reader/Punch . . . . .	2,067
Mag Tape Transports . . . . .	10,276
Cassette/Cartridge Transports . . . . .	4,257
Floppy Disk Drives . . . . .	9,909
Disk/Cartridge Drives . . . . .	13,285
Head-Per-Track Disk Drives . . . . .	3,033
Line/Serial Printers . . . . .	12,357
Teleprinters . . . . .	18,466
Add-on Memory (core) . . . . .	7,412
Add-on Memory (semiconductor) . . . . .	2,650
Digital Plotters . . . . .	809
Paper Tape Reader/Punch . . . . .	3,659
A to D, D to A Converters . . . . .	7,413

**minicomputers  
to be delivered to  
respondents in 1976**

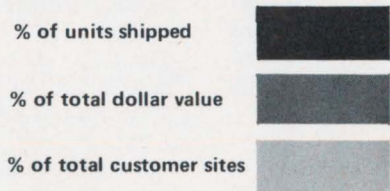

The survey report charts the percent share of the above prospective orders for all the major vendors including over 100 independent miniperipheral suppliers.

**TO ORDER**

To purchase a copy of the 1976 survey report, fill in the coupon and clip it to your letterhead or company purchase order. No telephone orders accepted.

**MODERN DATA SERVICES, INC**  
**5 Kane Industrial Drive**  
**Hudson, MA 01749**

Please enter my order for one copy of the 1976 *Minicomputer-Microprocessor Market Survey* at \$295 per copy including U.S. postage.

Payment enclosed       Bill me

Purchase Order number \_\_\_\_\_

Name \_\_\_\_\_

Company \_\_\_\_\_

Street \_\_\_\_\_

City \_\_\_\_\_ State \_\_\_\_\_ Zip \_\_\_\_\_

0 5 10 15 20 25 30 35 40 45 PERCENT CIRCLE NO. 36 ON INQUIRY CARD

## DATA LOGGER/READER

The 6100 Data Logger/Reader collects, digitizes and stores low frequency data on 3M cartridges. It is qualified to survive vibration per Mil-Std 810B Method 514. This, plus a self-contained 12 or 28-vdc power supply option, allow operation in automobiles, trucks, trains, boats, aircraft, and in the field. The data logger/reader accepts two 8-channel scanner cards. Depending upon the scanner cards selected, the inputs may

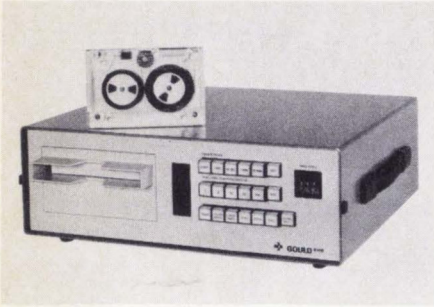

be all analog or up 6 digital and 10 analog. Scanning rates are 1, 5, 10, 50, 100 and 200 points per second. Available output card options provide interfacing to most minis and programmable calculators, and an ASCII interface outputs data to any RS-232 teleprinter or CRT. *Gould Inc., Cleveland, OH.*

Circle No. 147 on Inquiry Card

## INTERACTIVE MINI SYSTEM

The standard System 3000/Model 30 includes a 16-bit parallel central processor with 32K of 1-microsecond core memory, hardware multiply/divide, 9600-bps CRT console, dual disk drives and complete software. From there you can expand with more memory, disks, terminals, printers or mag tape. The software package includes the multiterminal operating system (MUX) with an optimized higher level language called Virtual BASIC. Price for the entire system is \$16,900. *Advanced Information Design, Los Altos, CA.*

Circle No. 170 on Inquiry Card

## PAPER TAPE READER

Known as the Model 640 Data Loader Series, these paper tape readers use LED light sources and hermetically sealed phototransistors. Power requirements for the LEDs is 12 vdc. The motor requires 115 vac, 10 watts. The readers read all standard five, six, seven or eight-level tapes at 350 characters per second. Single quantity price is \$151. *Addmaster Corp., San Gabriel, California.*

Circle No. 133 on Inquiry Card

## DISK FORMATTER

The Model XDF-76 Disk Formatter operates with 3340 type disk storage modules and provides for 40 to 1200-megabyte storage capacity, depending on the number of storage modules. Interfaces for most popular minicomputers are provided. Features include error correction codes, rotational position sensing and interleaving for consecutive sector transfers. Transfer rate is 128 K bytes per second. Price for a complete 100-megabyte system is \$13,200. *Xebec Systems, Inc., Santa Clara, CA.*

Circle No. 141 on Inquiry Card

## HIGH-SPEED TAPE TRANSPORT

The Floating Shuttle digital tape transport provides 75 inches per second bidirectional operation (equivalent to 120,000 bytes per second data rate) for PDP-11, Nova, and other mini-computer families. The transport handles 10-1/2-inch reels of 1/2-inch magnetic tape, providing either seven or nine-track operation, and may be operated in standard 800 bits per inch NRZI or 1600 bits per inch phase encoded. Single units are priced at \$4000, with quantity discounts available. *Qantex Div., North Atlantic Industries, Inc., Plainview, NY.*

Circle No. 143 on Inquiry Card

## MINI FLOPPIES

The *Series 8000 Communications RS-232 Data-Stor System* interfaces directly to all RS-232 terminals, printers and modems. It is designed around a microprocessor that uses a message-oriented directory for flexibility in storing and retrieving data. Single unit price is \$2500; dual unit price is \$3400.

The *Series 9000 Floppy System* offers 2.4 times the data capacity of the Sykes 7000 system. The disk controller is microprocessor-based and performs all searching, data blocking, CRC handling, address verification and head loading. Interfaces and software drivers are available for PDP-8, 11; Nova; HP-2100; and Interdata and Varian minis. Single drive system is \$2800; dual drive system is \$3900. *Sykes Data-tronics, Inc., Rochester, NY.*

Circle No. 189 on Inquiry Card

The *RFD 1000 Double Density Floppy Drive* provides up to 6.4M bits of data storage with MFM encoding recommended. Transfer rate is 500 kilobits per second. The RFD 1000 can also be used for single density data storage with a transfer rate of 250 kilobits per second. Unique to the Remex drive is the "enhancement" status connector — a feature which maximizes controller efficiency and interface flexibility in daisy chain configurations. The connector allows continuous individual monitoring of sector, index, ready and head load lines, permitting selection of a drive only when the CPU is assured that the drive is "Ready." Single quantity price is \$700. *Remex, Santa Ana, CA.*

Circle No. 193 on Inquiry Card

The *Model 270 Dual Diskette Drive* is said to be smaller than many single diskette drives. It's fully IBM 3740-compatible and has a capacity of 3.8 megabits per drive (1.9M bits on each diskette). A voice coil positioning system facilitates a random average seek in 33 milliseconds and a full stroke 76-track seek in 100 milliseconds. Price in quantities of 50 is \$880. *Per Sci, Inc., Marina del Rey, CA.*

Circle No. 191 on Inquiry Card

The *D-575 Disk Drive File System* expands the data handling capability of the Olivetti P-600 series micro-computers. It has a capacity of 271,000 characters and an I/O rate of 2K bytes per second. *BRD, Inc., Bainbridge IS., WA.*

Circle No. 192 on Inquiry Card

The *GSI-110 Flexible Disk Drive* will accommodate up to 6.4M bits of data on one side of standard media using the OEM's selection of MFM or M<sup>2</sup>FM encoding. Single density storage in variable formats provides up to 3.2M bits of data. The GSI-110 is also fully IBM compatible and will read and write IBM 3740-formatted diskettes for up to 1.9M data bits. Because GSI-110 was specifically designed for double density operation, the unit has these features: high accuracy ground lead screw, stable cast main frame, precise registration from stepper motor to spindle and a long-life ceramic read/write head. Price in quantity 100 is \$500. *General Systems International, Inc., Anaheim, CA.*

Circle No. 194 on Inquiry Card

# new products

## MATRIX PRINTER

Highlight of Model 2300 Matrix Printer is the high-speed servo technology, which enables speed vertical and horizontal tabbing, bidirectional printing, incremental printing and speeds up to 200 characters per second — all con-

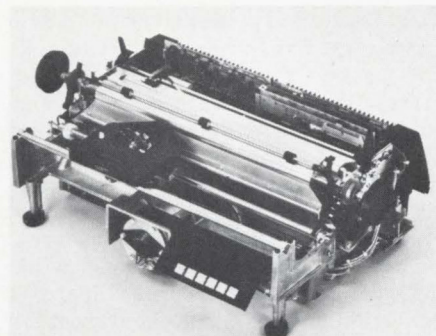

Diablo Systems' new Model 2300 Matrix Printer. Features a nine-wire head that permits printing both upper- and lowercase characters, a 9x7 matrix for finer print quality.

tributing to greater throughput. The microprocessor-controlled printer uses a 7x9 dot matrix and prints both upper- and lowercase. It uses the same solid, die case aluminum frame as the Diablo HyType serial printer. The ballistic head design of the 2300 permits the wire strikers to be in free flight, eliminating critical field head adjustments. *Diablo Systems, Inc., Hayward, California.*

Circle No. 150 on Inquiry Card

## LOW-COST MAG TAPE

The MicroVox Mag Tape Drive can be plugged into any 115-volt outlet and terminates in a standard 20-ma loop and RS-232C connectors. It operates at data rates of 110, 300, 600 and 1200 baud, and it is fully double buffered and capable of operating under both local and remote control. The Mag Tape Drive stores 20,000 ASCII characters on a magnetic tape wafer that sells for \$3.50 in single quantity. Price for the peripheral is \$895. *Micro Communications Corp., Waltham, MA.*

Circle No. 178 on Inquiry Card

## PAPER TAPE PUNCH

The 6110 paper tape punch is 4x4x6 inches and is equipped with a brushless transistorized DC motor. Operation of the punch is at 50 characters per second. The 6110 can accommodate five, six or eight channels on 1-inch, 7/8-inch or 11/16-inch ANSI standard paper tape. *Epson America, Inc., Torrance, California.*

Circle No. 131 on Inquiry Card

## MICROPROCESSOR TESTER

The MPU-1 Microprocessor Test System is a dedicated tester for four- and eight-bit microprocessor chips. Included in the system are a 4K RAM, 512 words of PROM, control panel, teleprinter interface and comprehensive test program. The test program is loaded with either paper tape or optional tape cartridge and exercises the chip using all instructions and performs a test of all registers and the arithmetic logic unit. The MPU-1 is also useful as a software development system. New programs can be entered from the front panel in machine code from the teleprinter keyboard using the system monitor and by reading paper tape. The price is \$12,200. *Micro Control Co., Minneapolis, MN.*

Circle No. 127 on Inquiry Card

## TAPE FOR MICROS

Measuring 3x3x1.8 inches and weighing 16 ounces (complete with electronics), the Mini-Raycorder has a data capacity of 64K bytes/side (unformatted), a packing density of 800 bits per inch,

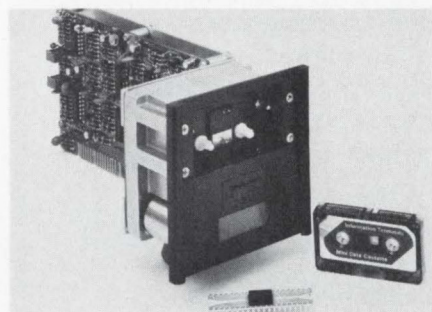

and a data transfer rate of 2400 bits per second. The cassette recorder consumes less than 2 watts of power, operating at 5.0 vdc. Designed specifically for use with microprocessors, the Mini-Raycorder is priced at \$225. *Raymond Engineering, Inc., Middletown, CT.*

Circle No. 183 on Inquiry Card

## PRINTER AND COMMUNICATIONS CONTROLLER

The Media III 2804 multiplexer board for Data General minis contains four asynchronous communications channels, a 100-Hz real time clock and a parallel line printer interface to a Centronics, Data Products, Tally, or Printronix line printers. The board can also contain an optional Teletype I/O channel. Switches in each communications channel allow baud rate selection in seven steps from 110 to 9600 baud. *Media III, Anaheim, CA.*

Circle No. 129 on Inquiry Card



**Accupower™**, the uninterruptible power system from Emerson is now keeping over 200 computer installations on line.

You'll get an all solid-state design ...and protection from outages, brownouts and fluctuations. Plus complete voltage frequency and transient control.

Carefully check all the Accupower™ features. Including its design simplicity, high reliability and efficiency, and easy maintenance. Minimum installation costs.

The number of repeat customers is an excellent way to judge performance...Emerson will show you the largest list of repeat customers in the industry. Call (714) 545-5581. Or write Emerson Electric Company, attention UPS Marketing, 3300 South Standard St., Santa Ana, Ca. 92702.

CIRCLE NO. 28 ON INQUIRY CARD

# new software & services

## COBOL PROGRAM GENERATOR

The Cobol Optimizing System (COSY) is a COBOL program generator that combines automatic procedures along with a free format input language to produce a fully structured COBOL program. COSY is available under IBM DOS/OS and is being offered on a trial basis for \$1500 per month. *C-S Computer Systems, Inc., New York, NY.*

Circle No. 207 on Inquiry Card

## MULTI-USER PDP-15 XVM

Multiple users can access simultaneously a PDP-15 or XVM system for general-purpose computing with Multiaccess, a multi-user version of Digital's XVM/RXS software system. Multiaccess is designed for from two to six concurrent users, and will accommodate as many as 16 terminals, depending upon the amount of system memory and disk storage space available. Available through license, Multiaccess prices start

at \$2750 for a software upgrade to existing RSX users. The Multiaccess license for new XVM systems is available for \$6000. *Digital Equipment Corp., Maynard, MA.*

Circle No. 203 on Inquiry Card

## DATA ENTRY AUDIT

The Data Entry Department Audit service is a fixed-price product to help data entry departments operate at maximum efficiency. Areas evaluated are: operator performance, work flow, physical environment, organizational structure, salary policies, staffing caliber, employee policies, morale and department operating budget. For a typical data entry department of 25 work stations, the audit requires approximately four weeks at a fixed price of \$4500. *Advanced Keyboarding Systems, New York, NY.*

Circle No. 205 on Inquiry Card

## OS FOR 360/370

DOS/MVT is a new operating system for IBM 360 and 370 computers. It is fully compatible with Release 26 of IBM's Disk Operating System (DOS) and will run on any CPU with at least 192K of memory. Although DOS/MVT is a total rewrite of IBM's DOS, all user programs can function under DOS/MVT without modification. A special feature of DOS/MVT is that it controls 12 batch regions. It has also eliminated all partition dependency. All regions are functionally the same; each is capable of executing any program. Monthly fee is \$500. *Software Pursuits, Mill Valley, CA.*

Circle No. 212 on Inquiry Card

## ASSEMBLER FOR INTEL SDK

Designed for Intel's 8080-based System Design Kit (SDK) microcomputer, this assembler is a resident assembler rather than a cross-assembler, (i.e., it runs directly on the machine for which the source code is written). Its major features include full compatibility with existing assemblers; relocatable object code; and one, two, or three-pass operation. The assembler can process complex expressions, and a full range of error diagnostics is provided, including the capability to detect a symbol table overflow. It occupies less than 4K bytes of storage, and the object code it produces can be run on any 8080-based microcomputer. Available on four pre-programmed PROM chips, it costs \$450. *Microcomputer Technique, Inc., Reston, VA*

Circle No. 202 on Inquiry Card

## MORE PERCEPTIVE and MORE INFORMATIVE

the newest service to the newest  
Billion-Dollar Industry its name

## mini-micro news

a fortnightly newsletter

MINI-MICRO NEWS is *Mini-Micro Systems'* fortnightly hotline serving the users, vendors, and observers of mini-computers, microcomputers, microprocessors, small business computers, miniperipherals, minisoftware, intelligent and remote batch terminals, word processing systems, data entry systems, industrial automation systems, and all of the variety of products which make this the most exciting of all industries.

### NEWS / INTERPRETATION / ANALYSIS / FORECASTS

Flashing the news quickly to its readers  
is only one of the services of MINI-MICRO NEWS

*Mini-Micro Systems* has always been ahead of the field in perceiving long-term trends, in addition to its major strength in organizing and classifying the products in our fast-changing industry. *Mini-Micro Systems'* offspring, MINI-MICRO NEWS, reports and analyzes the up-to-the-minute news against the background of what we perceive to be the direction of the industry.

### ALL THIS AND CPC TOO

The Computer Product-Line Clearinghouse, a constant feature of MINI-MICRO NEWS, provides, for the first time *anywhere in any industry*, a free medium of exchange between potential buyers and sellers of rights to product-lines, inventions, subsidiaries, whole companies, etc.

In the boom years to come, you can't afford to miss CPC.

### Subscription Department

MINI-MICRO NEWS / 5 Kane Industrial Drive / Hudson, MA 01749

- PAYMENT of \$65 is enclosed for a 1 year's subscription (26 issues)  
 Bill my company. P.O. # \_\_\_\_\_  Bill me later  
(add 5% handling & postage)

Note: for air mail outside US/Canada - add \$20.

NAME \_\_\_\_\_ TITLE \_\_\_\_\_

COMPANY \_\_\_\_\_

STREET \_\_\_\_\_

CITY \_\_\_\_\_ STATE \_\_\_\_\_ ZIP \_\_\_\_\_

# new literature

## MCI'S EXECUNET

The advantages of the ExecUNET Service are detailed in this series of free brochures. The brochures show how savings of 30 percent and more are possible with ExecUNET Service, how ExecUNET Service is a valuable cost-allocation tool and which cities are part of the ExecUNET system. MCI's ExecUNET is a shared private line service connecting 15 major metropolitan areas. *MCI Telecommunications Corp., Washington, DC.*

Circle No. 267 on Inquiry Card

## NUMERICAL CONTROL CATALOG

This catalog describes the Acramatic Computer Numerical Control as applied to turning centers and profilers as well as machining centers. Illustrated and described are the significant features of the control, including: full contouring, fixed cycles, tool management, system support, diagnostics, productivity, reliability, and CRT display. *Cincinnati Milacron, Lebanon, OH.*

Circle No. 253 on Inquiry Card

## TIMING PRODUCTS CATALOG

Six time code instruments, their features and typical system applications, are described in this 10-page timing products catalog. Included are time code generators, translators, remote displays, timing terminal units, plus a search and control unit, all available with computer interfaces. *Moxon Inc., Irvine, CA.*

Circle No. 257 on Inquiry Card

## PERIPHERALS CATALOG

A complete list of equipment available from Continental Peripherals is contained in this brochure. The rental, leasing, and service capabilities are described for computer peripherals such as the DECwriter II, TI's Silent 745, Diablo's Hyterm 1620, Lear Siegler's CRTs and Anderson Jacobson's acoustic couplers. *Continental Peripherals, Bedford, MA.*

Circle No. 252 on Inquiry Card

## NUMERICAL CONTROL TAPE

The NC-9 numerical control tape preparation and communication system is described in this four-page brochure. The system is designed for offline editing and for online computer assist. *International Computer Products, Inc., Dallas, TX.*

Circle No. 259 on Inquiry Card

## MICOS APPLICATION

The application of the Micos minicomputer system in the apparel industry is described in this 12-page brochure. The Micos system provides order entry, invoicing, inventory control and accounts receivable services for Goldworm, a major ladieswear firm in New York. *Mini-Computer Systems, Inc. Elmsford, New York.*

Circle No. 269 on Inquiry Card

## APL-BASED COMPUTERNET

This nontechnical 16-page booklet describes Computernet, a worldwide information network using an enhanced version of APL. A centerfold chart shows the feature-by-feature evolution of the company's APL version from IBM's original. The booklet also contains printouts and describes the main features of several proprietary "U-Write" programs that allow non-technical users to write their own management report-generating routines, PERT programs, and statistical analyses using English commands. *Proprietary Computer Systems, Inc., Van Nuys, CA.*

Circle No. 266 on Inquiry Card

## OEM POWER SUPPLIES

The OEM designer has the information needed to select standard single and triple-output switching-regulated power supplies in the 110 to 600-watt range with this 20-page catalog. Illustrated with photos, diagrams, tables and graphs, the catalog provides special output-rating boundaries for modified switching and linear-regulated supplies, reliability-test results, prices, UL numbers and equipment-cooling guidelines. *Hewlett-Packard Co., Palo Alto, CA.*

Circle No. 278 on Inquiry Card

## 1K RAM

The MW7001ID NMOS random-access memory data bulletin includes detailed dynamic and static electrical characteristics, temperature characteristics, test circuits, waveforms, and typical driving and sensing circuits. An application note on the 1K RAM describes input loading of the device, recommended interface circuits and options, operation of the internal charge pump and systems considerations. *RCA/Solid State Division, Somerville, NJ.*

Circle No. 251 on Inquiry Card

## Line Transients can cause **BIG MISTEAKS!**

Protect your computer data with HOLLAND'S  
**PowerGuard®**  
Transient Voltage Alarm and Recorder.



- Detects and measures power line fluctuations
- Strip Chart Recorder verifies amplitude and duration of transients
- Automatic Alarm signals transient occurrence in AC power line
- Low cost protection of data integrity . . . only \$1485

**Chart Recorder . . .** starts data recording at the moment transient is detected.

**Alarm . . .** red light and audible alarm indicate entry of high speed transient.

**HOLLAND ELECTRONIC'S** unique PowerGuard has been selected by General Electric leasing as one of the ten most wanted instruments in the industry.

Call us today for a demo and save time and money on expensive reworks of computer data.



**HOLLAND ELECTRONICS, INC.**  
970 East 92 Street  
Brooklyn, New York • 11236  
212-649-7330

CIRCLE NO. 38 ON INQUIRY CARD

# DATASCOPE

a new diagnostic tool for  
data communications systems

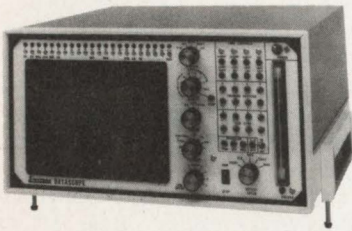

**Operates on-line to:**  
**MINIMIZE DOWNTIME**  
**PINPOINT SYSTEM**  
**FAILURES**  
**DEBUG SOFTWARE**

- Provides CRT display of every data link character, sent or received
- Simultaneous full duplex data stream tape recording
- Accepts all codes, line disciplines and speeds up to 9600 bps
- Switch selectable alphanumeric or hexadecimal display
- Monitors full and half duplex circuits
- Printed record available on standard teletype printer
- Designed for operating personnel, programmers and engineers
- Compatible with EIA Interface RS-232
- Lamp display of all EIA Interface signals
- Complete electrical isolation from monitored channel
- Lightweight portability . . . single compact unit
- Simple, straight forward connection



CHURCH ROAD & ROLAND AVENUE  
MOORESTOWN, N. J. 08057  
609 - 234 - 5700

CIRCLE NO. 29 ON INQUIRY CARD

## index to advertisers

APPLIED DIGITAL DATA SYSTEMS. . . . .	8, 9
BOWERS ENGINEERING CO . . . . .	48
CLARY CORP . . . . .	37
COMPUTER OPTICS, INC . . . . .	11
DATA GENERAL . . . . .	7
DELTEC CORP. . . . .	40
DIABLO SYSTEMS, INC. A XEROX CO. . . . .	Cover 4
DIGI-DATA CORP. . . . .	20
EDUCATIONAL DATA SYSTEMS . . . . .	10
ELGAR CORP . . . . .	23
EMERSON ELECTRIC CO. INDUSTRIAL CONTROLS DIV . . . . .	27
EMERSON ELECTRIC CO. UPS MARKETING . . . . .	61
EXIDE POWER SYSTEMS DIVISION. . . . .	2, 3
FROST & SULLIVAN, INC. . . . .	47
HAZELTINE CORP. COMPUTER TERMINAL EQUIPMENT. . . . .	Cover 2
HEWLETT-PACKARD. . . . .	12, 13
HOLLAND ELECTRONICS, INC . . . . .	63
IBM CORP. . . . .	15, 16, 17, 18
INSTRUMENTATION AND CONTROL SYSTEMS, INC. . . . .	22
INTERNATIONAL POWER MACHINES CORP . . . . .	29
INTERNATIONAL RESOURCE DEVELOPMENT INC. . . . .	48
C. ITOH ELECTRONICS, INC . . . . .	38
MINI-MICRO SYSTEMS. . . . .	46, 56, 62
MODERN DATA SERVICES, INC. . . . .	58, 59
MODULAR COMPUTER SYSTEMS. . . . .	24, 25
NCR CORP . . . . .	41
POWER SYSTEMS & CONTROLS, INC. . . . .	37
PROGRAMMED POWER INC. FRANKLIN ELECTRIC. . . . .	35
ROBINS INDUSTRIES CORP. DATA PRODUCTS DIV. . . . .	43
ROYTYPE DIV. OF LITTON IND. . . . .	39
SCIENTIFIC BUSINESS SYSTEMS, INC . . . . .	21
SPECTRON CORP . . . . .	64
SYSTEM INDUSTRIES . . . . .	57
TAB PRODUCTS CO. . . . .	43
TELEDYNE INET . . . . .	33
TELETYPE CORP . . . . .	1
TEXAS INSTRUMENTS INC. . . . .	4
TOPAZ ELECTRONICS. . . . .	38
TRI-DATA CORP. . . . .	Cover 3
WRIGHT LINE INC . . . . .	14
ZENTEC CORP. . . . .	49