

The complexity of bit-slice processor parts, compounded by minimal support from their manufacturers, has won them a poorer welcome than they deserve from designers. Although processors built with bit slices can be extremely powerful, the design flexibility of the parts in both hardware and instruction sets demands an intimate familiarity with a particular family before a designer can be confident of success.

The article that follows opens a two-part series intended as an introduction and general comparison of the various bit-slice products available. Based largely on the authors' many years of experience, it also draws upon the work they did at the Applied Research Laboratories of the University of Texas at Austin on the development of a bit-slice-based sonar interface controller for the Naval Sea Systems Command.

The first article is devoted to the processor element—the chip that manipulates the data. The second deals with the other half of basic bit-slice design—the microcontroller that sequences the instructions—as well as the support products and literature supplied by the manufacturers of families of bit-slice parts. It will appear in the next issue.

How bit-slice families compare: Part 1, evaluating processor elements

by W. Thomas Adams and Scott M. Smith, *

Applied Research Laboratories, University of Texas, Austin, Texas

□ When they first came on the market, bipolar bit-slice processors were almost totally unsupported by surrounding circuits or design aids, much less by documentation or even advertising. Then, as more device types were brought out by the various manufacturers, it seemed that users had even less way of knowing which bit-slice processors were best suited to their applications.

What follows is a comparative survey, as complete and objective as possible, of both the parts available and the design support offered by the various manufacturers. Such a survey is all the more necessary because of the high level of skill needed to build a bit-slice processor.

Designing with a byte-oriented metal-oxide-semiconductor microprocessor, after all, consists mainly of programming a system made up of components hooked together according to the manufacturer's specifications. But bit-slice processor design involves critical hardware decisions and the creation of an instruction set as well—and only then comes the programming. Moreover, since bit-slice processor parts of different manufacturers can be mixed in one and the same design, consideration must be given individually to each of them.

A look back

In 1974, Monolithic Memories Inc. introduced the first bit-slice microprocessor device, the 4-bit-wide 6701 processor element, though it was marketed as a microcontroller rather than a microprocessor. No family of surrounding circuits and no design aids of any kind were offered to make its use any easier. In 1974 and early 1975, Intel Corp. and Advanced Micro Devices Inc. introduced families of bipolar large-scale integrated circuits promoted as "bipolar microprocessors." That marketing strategy, together with the wide acceptance of the MOS processors, brought customers' attention to the bit-slice devices. These three manufacturers were then joined by Fairchild Camera & Instrument Corp., Texas Instruments Inc., Scientific Micro Systems, Motorola Inc., Raytheon Corp., Signetics Corp., and National Semiconductor Corp., so that now there is a wide variety

*Both authors are now at IBM Corp., Office Products Division, Austin, Texas.

of bit-slice processor parts available to choose from.

A bit-slice processor is built with a multiple-chip set of large-scale integrated circuits that handle data not in complete bytes or words but in 2- or 4-bit chunks. Most often it uses transistor-transistor-logic technology. Such a processor has several features that make it attractive for applications requiring performance beyond the capability of the byte-oriented MOS devices or even such bipolar microprocessors as Texas Instruments' SBP9900 or Signetics' 8X300. These applications include mini-computers, high-speed peripheral controllers, signal processors, and some types of stand-alone process controllers. Also, bit-slice designs use fewer parts than a system built with discrete logic, though they do require more components than other microprocessor designs.

Bit-slice systems are microprogrammable: the designer himself—not the device manufacturer—determines the instruction set of a given processor. Such a feature is invaluable for emulating an existing machine, for example. In addition to being expandable in terms of processor and control-memory word widths, the bit-slice devices are expandable in processing power. Auxiliary arithmetic processors, special input/output devices, and other features may be added to the basic design to provide virtually any reasonable processing capability.

At present, there are six families of devices classified as bit-slice microprogrammable processor sets. These are the 6701/67110 from Monolithic Memories, Intel's 3000

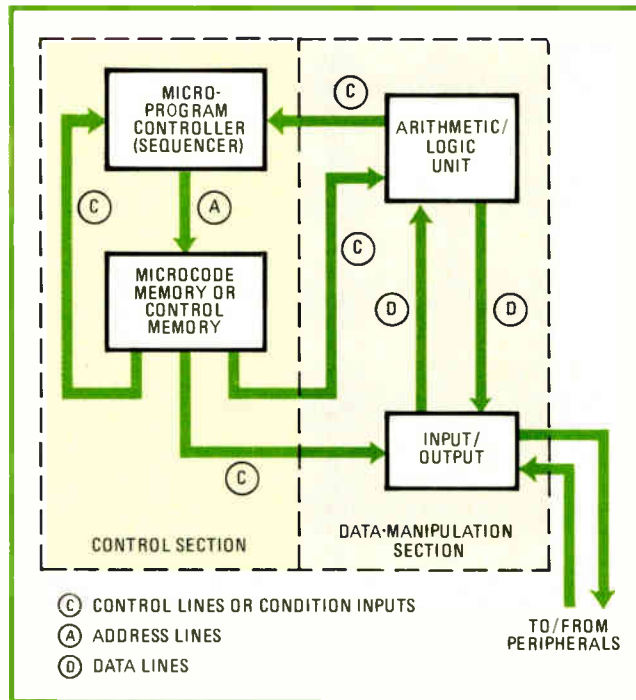

1. Bit-slice basics. Two sections make up a bit-slice processor. One, built around the processor-element chip, manipulates the data. Control and sequencing of microinstructions is handled by the second section, which is built around the microcontroller chip.

TABLE 1: GENERAL CHARACTERISTICS AND ARCHITECTURAL FEATURES OF THE PROCESSOR ELEMENTS

Bit-slice device	Manufacturer	Second sources	Technology	Slice width (bits)	Pins/pack	Typical power required (mW)
9405	Fairchild	Sig	Schottky TTL/C MOS	4	24 DIP	500 (TTL)
3002	Intel	Sig	Schottky TTL	2	28 DIP	725
6701	MMI	ITT	Schottky TTL	4	40 DIP	1,075
Am2901(A)	AMD	Fairchild, MMI, Mot, Ray, Sig, Nat'l	Schottky TTL	4	40 DIP 42 FP	925
SBP0400A SBP0401A	TI	—	I ² L	4	40 DIP	1,000 ⁶ (programmable)
SN74S481	TI	—	Schottky TTL	4	48 QIP	1,125
MC10800	Mot	Fairchild	ECL	4	48 QUIL	1,374
Am2903	AMD	Nat'l	Schottky TTL	4	48	1,155

¹ Indicated as accumulators + register file + buffer registers.

² Two registers in register file are addressed simultaneously.

³ The program counter is part of the register file, but also serves as a buffer register.

⁴ Devices intended to be used with external register-file parts.

⁵ The program counter and memory counter are incrementable registers and, in addition, the former feeds back into the 74S481's ALU section.

⁶ Has a mask input (2 lines) that may be forced to all 1s or 0s requiring 1 extra bit of control or up to N bits for an N-bit processor if each bit is controlled separately.

TABLE 2: ARITHMETIC AND LOGIC CAPABILITIES OF PROCESSOR ELEMENTS

Bit-slice device	Logical operations ¹	Add/subtract operations ²	BCD add	Multiply	Divide	Cyclic redundancy checking generator	Normalize	2's complement sign/magnitude conversion	Parity	Decoded status ³
9405	C,A,O,EO	A	-	-	-	-	-	-	-	Z
3002	C,A,O,EN	A,D1,2C	-	-	-	-	-	-	-	Z ⁴
6701	C,A,O,EO	A,S,D1,2C	-	-	-	-	-	-	-	O,Z
Am2901(A)	C,A,O,EO,EN	A,S,D1,2C	-	-	-	-	-	-	-	O,Z
SBP0400A SBP0401A	C,A,O,EO,EN	A,S,I1,2C	-	-	-	-	-	-	-	Z
SN74S481	C,A,O,NA, NO,EO,EN	A,S,I1,D1, 2C	-	yes	yes	yes	-	-	-	O,E,AG,LG
MC10800	C,A,O,NA,NO EO,EN	A,S,D1,D2, I1,I2,2C	yes	-	-	-	-	-	yes	O,Z
Am2903	C,A,O,NA,NO, EO,EN	A,S,I1,I2 2C	-	yes	yes	-	yes	yes	yes	O,Z

¹ Logical operations are:

- C Complement
- A AND
- O OR
- NA NAND
- NO NOR
- EO Exclusive-OR
- EN Exclusive-NOR

² Add/subtract operations are:

- A Add
- S Subtract
- Di Decrement by i
- Ii Increment by i
- 2C 2C 2's complement

³ Decoded status is:

- O Overflow
- E Equal
- Z Zero
- AG Arithmetic greater than
- LG Arithmetic less than

⁴ Indicated on carryout line during logic operations only.

Registers ¹	Data ports			Control lines
	Input	Output	Bidirectional	
0 + 8 + 1	1	1	0	8
1 + 11 + 1	3	2	0	9 ⁶
1 + 16 ² + 0	1	1	0	17
1 + 16 ² + 0	1	1	0	18
2 + 8 + 0 ²	1	2	0	11
2 + 0 ⁴ + 2 ⁵	1	2	1	17 ⁷
1 + 0 ⁴ + 1	1	0	2	17 ⁷
1 + 16 ² + 0	1	0	2	21

⁷ Does not include bits necessary to address an external register file if one is used.

⁸ The SBP0400A/SBP0401A specs are written for 200-mA injector currents. If a 5-V supply is used, total power required by device and injector resistor is 1,000 mW. Both are maximum-speed configurations.

series, Advanced Micro Devices' 2900 series, the Macrologic series from Fairchild, Texas Instruments' 74S481/82 and SBP0400, and the 10800 series from Motorola. The manufacturers market their parts as families of devices that are to be used together to implement a processor.

The basics of a bit-slice processor are illustrated in Fig. 1, which shows a system divided into a control or sequencing section and a data-manipulating section. Accordingly, the two basic parts in any bit-slice family are the microcontroller, which sequences the microinstructions, and the processor element, or arithmetic and logic section. A given bit-slice family may also contain several parts that perform special functions, acting as controllers for interrupt, memory, and input/output, for instance. Other devices like random-access memories, programmable read-only memories, and bus drivers may be marketed as family members or separately.

The processor elements

The processor element consists basically of an arithmetic and logic unit and associated registers. It gives the bit-slice microprocessor its name, because it generally handles data 2 or 4 bits wide at a time. The 2- or 4-bit slices are cascaded to form arithmetic processors of the desired word size. Table 1 lists the general characteristics and architectural features of the processor elements. The ALU instruction capabilities of each of the processor elements are shown in Table 2.

The 9405 from Fairchild (Fig. 2) is a relatively simple processor element. It can, however, be combined with Fairchild's 9404 data-path switch (also shown) to obtain a more capable arithmetic processor. Although a two-

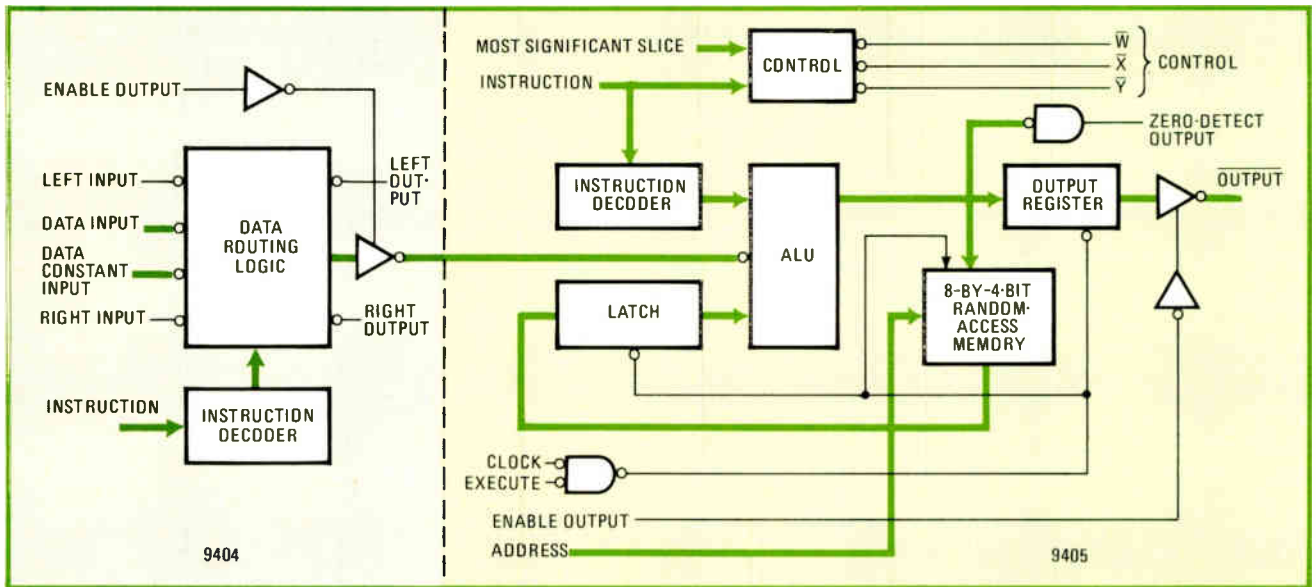

2. Two-chipper. Fairchild's 9405, a relatively simple processor element, becomes a capable arithmetic processor when hooked to a 9404 data-path switch. The chip set is also available in a complementary-MOS version ideally suited for low-power applications.

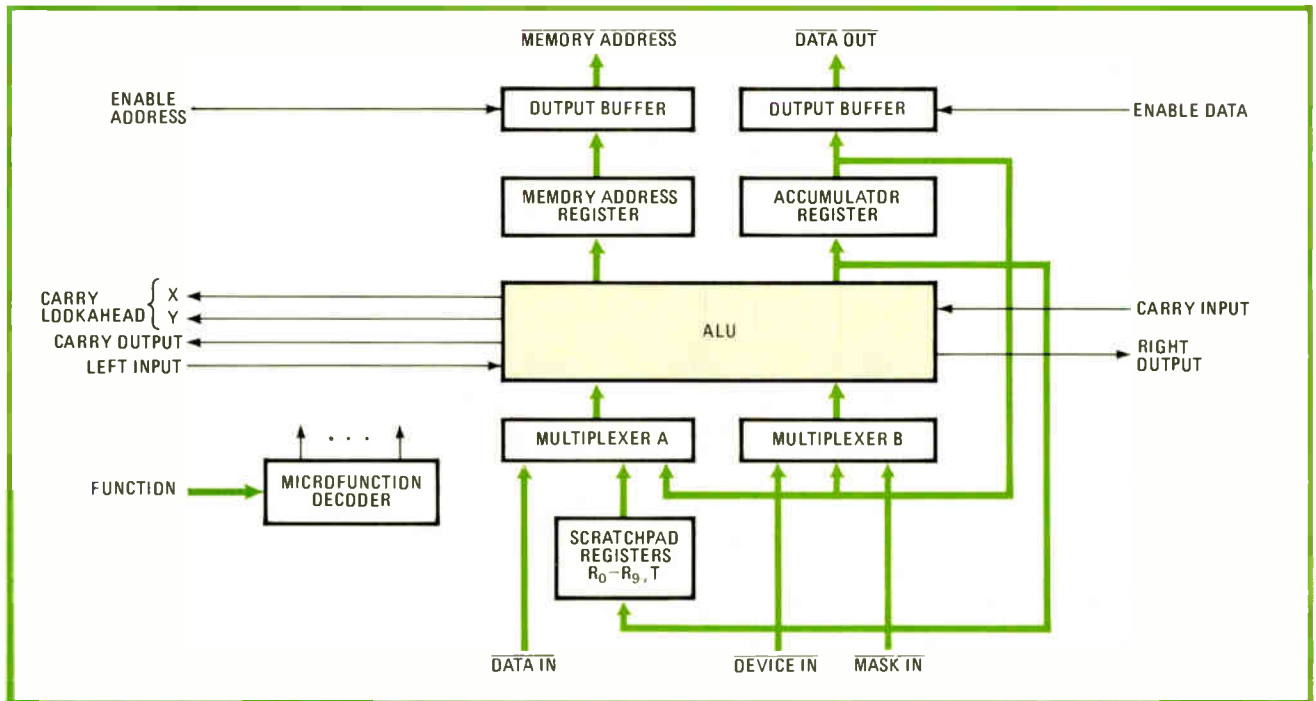

3. Two bits. One of the earlier processor-element designs is Intel's 2-bit-wide 3002. Twice as many 3002s as 4-bit devices are required to build a processor of a given width, but the Intel part compensates by offering more I/O ports than any other processor element.

chip set results, each device is housed in a space-saving 400-mil-wide 24-pin package.

Being on the lower end of the performance scale, the 9405 is best suited for controller and processor applications that are just beyond the capabilities of the MOS and bipolar microprocessors. A plus is that complementary-MOS versions of the 9404 and 9405, ideally suited to low-power applications, are also available.

Figure 3 shows one of the earlier designs, the Intel 3002. Since it handles only a 2-bit-wide slice, twice as many 3002s as 9405s are required to implement a processor of a given width. However, Intel's part

compensates by offering a larger number of I/O ports than any other device.

Since the 3002 has a single-port register file, more instructions may be required for some tasks. The trade-off here is the increased number of instructions—and longer execution time—versus the larger number of control lines required for the multiple-port register file.

With its excellent I/O capabilities, the 3002 works better in data-manipulation applications than in number crunching. Signetics offers a version, the N3002, that is significantly faster than Intel's original part.

Although not exactly identical, Monolithic Memories'

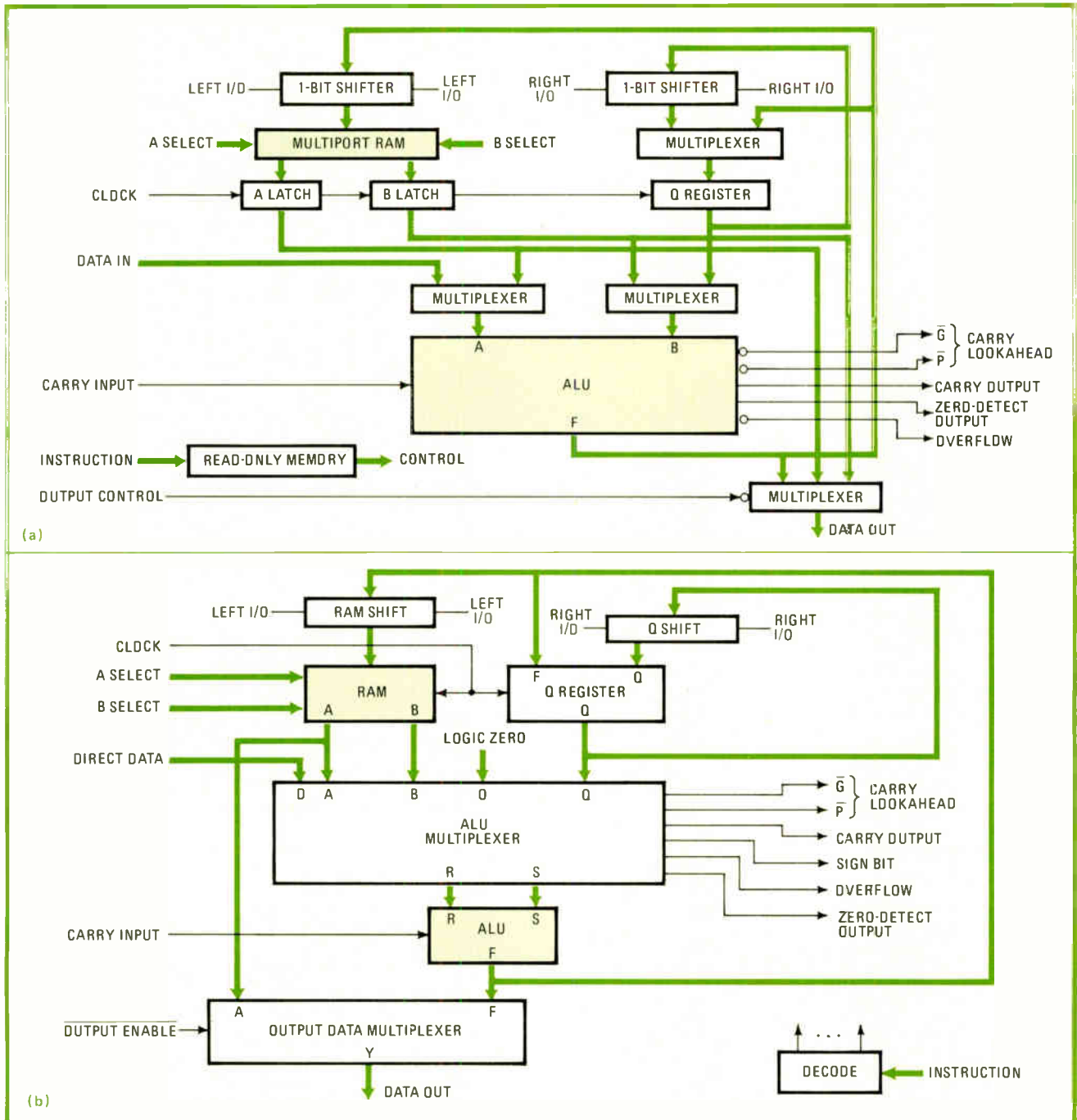

4. Similar slices. The 6701 from Monolithic Memories (a) and the Am2901 from Advanced Micro Devices (b) are architecturally similar processor elements. Outstanding in these are the dual-port, 16-register files and the cascading of ALU and shift matrixes.

6701 and AMD's Am2901 are quite similar architecturally, as can be seen in Fig. 4. The dual-port 16-register file and cascading of the ALU and shift matrixes are the most outstanding features of these processor elements. A separate accumulator with its own shift network is also provided to facilitate multiply and divide operations.

The I/O port structures of the 6701 and 2901 might at first seem limited, but are sufficient in most cases. These devices are competent to handle a large number of minicomputer and controller applications (as evidenced in particular by the sales record of the 2901). A higher-speed version of the 2901, the 2901A, is also available.

There are several other higher-speed versions of the 2901, including an interesting one from National Semiconductor that integrates emitter-coupled logic within the TTL framework. The designer should be aware when using such devices, however, that the slower versions may no longer work in his design, so that he may no longer have a second source.

Texas Instruments' first commercial device to use digital integrated injection logic was the SBP0400 bit-slice processor element (Fig. 5). However, it is slower than any of the TTL processor elements, as is even a later and much faster version, the SBP0400A. The SBP0400's

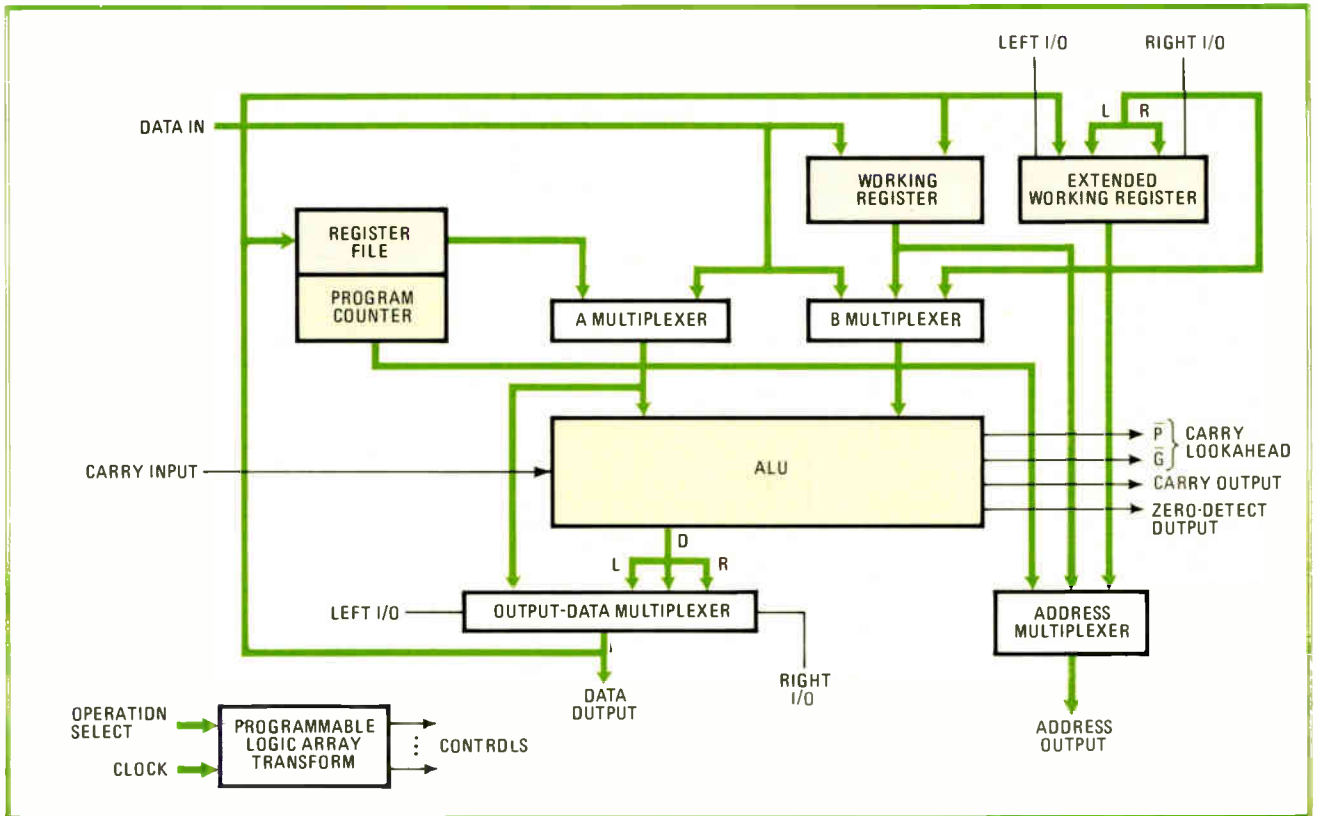

5. PL version. Texas Instruments' SBP0400, built with integrated injection logic, runs more slowly than TTL processor elements. Unique to the devices, however, is a programmable power dissipation that can be selected over a 1,000:1 range for a constant speed-power product.

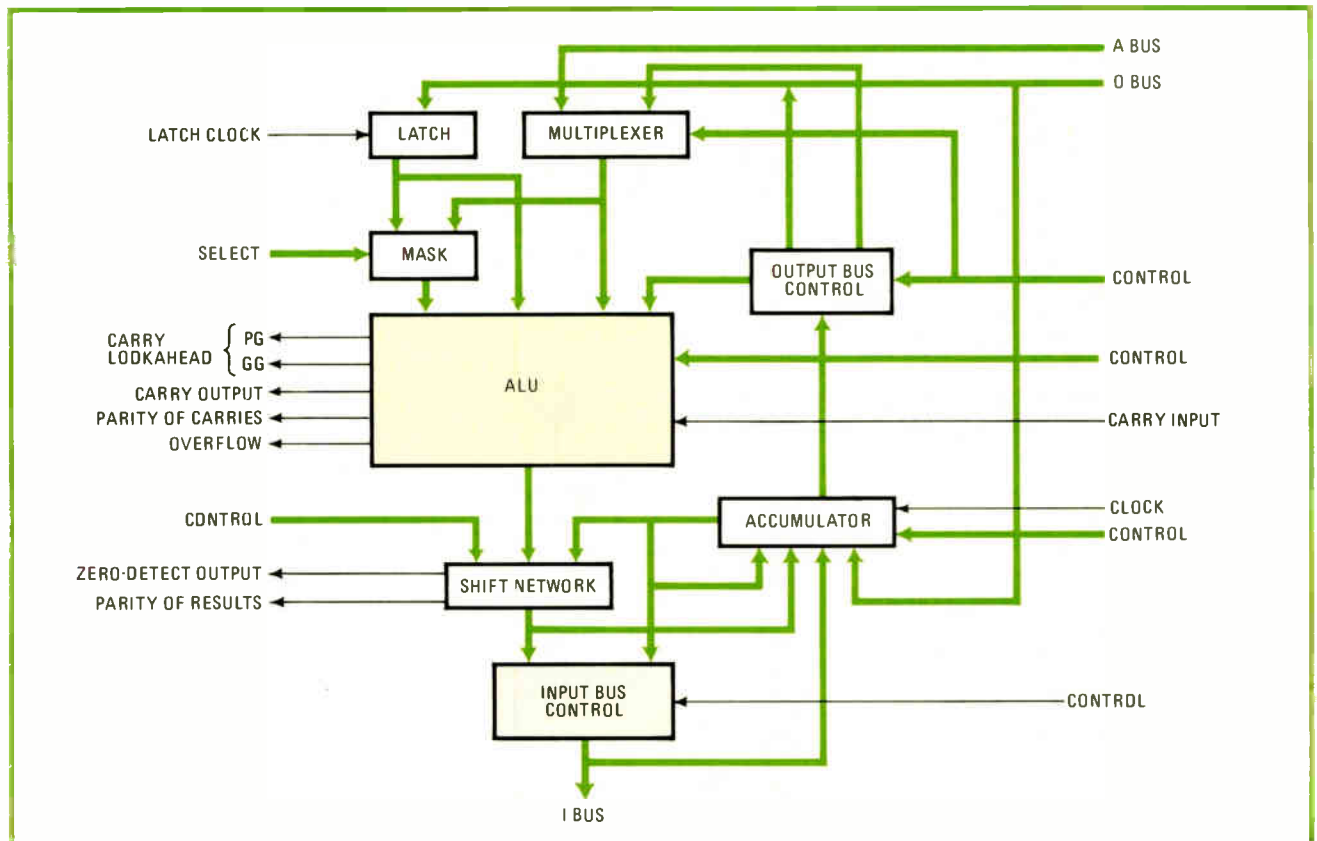

6. All ECL. The only processor element built entirely of emitter-coupled logic is Motorola's MC10800. Its pluses include binary-coded-decimal addition and internal parity generation for error checking. Mixing the ECL part with TTL bit-slice families is generally not recommended.

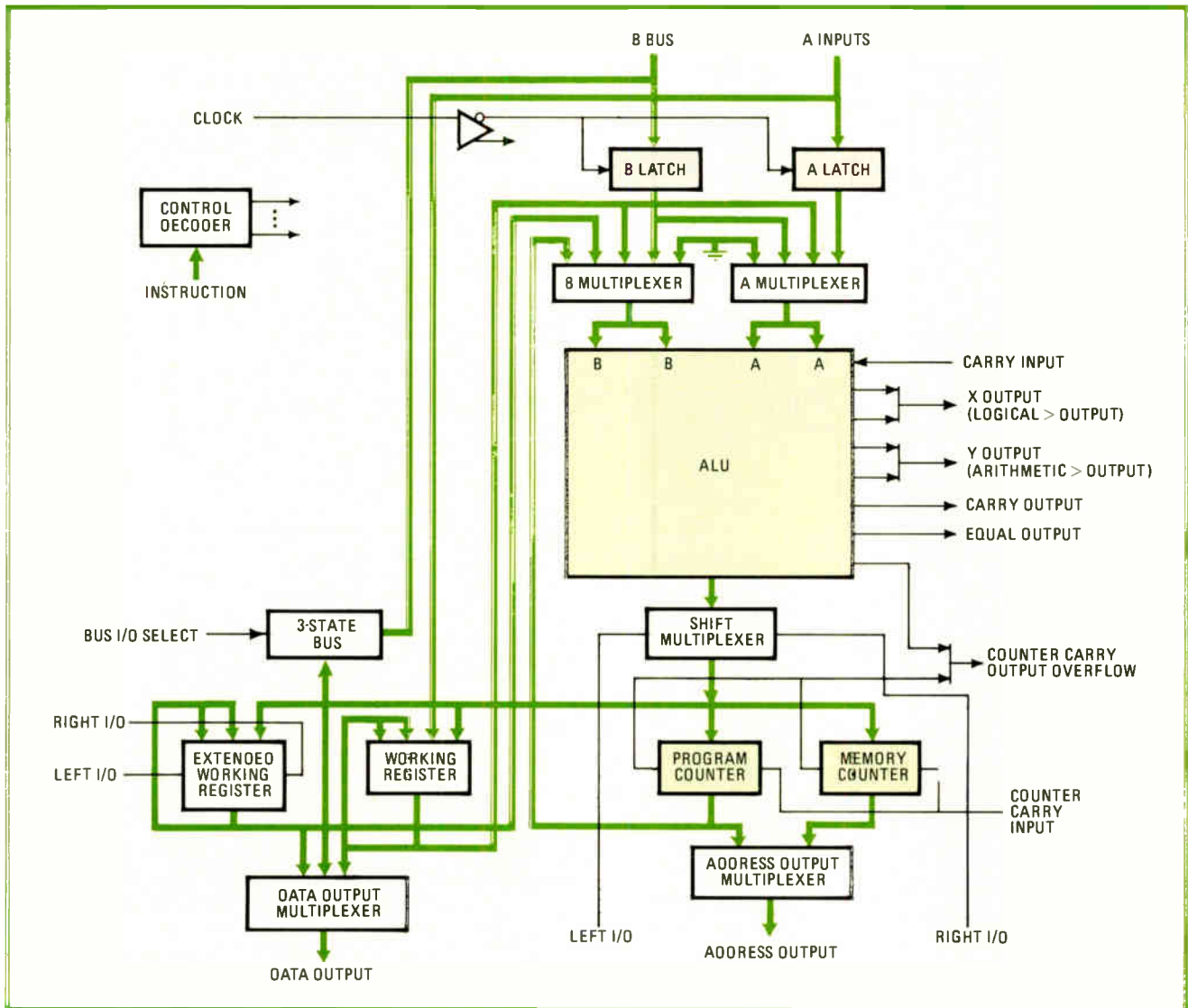

7. Complex. Structurally the most complex processor element available is Texas Instruments' SN74S481. Because of strong arithmetic capabilities, including preprogrammed multiply and divide, the part is optimized towards minicomputer and signal-processing applications.

most outstanding feature is its programmable power dissipation. The power it uses can be programmed over a 1,000-to-1 range while the speed-power product remains constant. But the device would be much more useful if there were other i^2L parts to go with it.

The SBP0400 has several convenient features. Although its register file is essentially a single-port unit, one register designated the program counter may be accessed separately through the address port. What's more, a separate accumulator and extension are provided to support multiply and divide operations, and those registers may be accessed directly through the address port. Any register in the register file may be accessed directly through the data port, bypassing the ALU. In sum, the design of the SBP0400 is convenient and well thought out, but the i^2L technology decreases its usefulness in high-throughput applications.

Motorola's MC10800 (Fig. 6) is the only processor element built entirely with ECL and is the fastest part in the group. Although the 10800, like the 74S481, lacks an internal register file, it has an I/O-bus configuration that

easily supports an external file. One register file device in the family, the MC10143, has two input ports and one output port; since all of its ports are separately addressable, it is tailored to implementing external register files in MC10800 designs.

While the 10800 has no built-in multiply or divide hardware, it can be microprogrammed to perform these operations. It is unique, however, in providing binary-coded-decimal addition, and it is one of only two devices that provide internal parity generation for error control.

In general, the use of the 10800 with members of the TTL bit-slice families is not recommended in the processor itself because of the required logic level translation and the inherent differences in speed potential between ECL and TTL. The 10800 is a member of a well-designed family of parts that is optimized for use in minicomputers, signal processors, and some types of controllers.

The most complex processor element available is TI's 74S481 (Fig. 7). In number of input and output ports, the 74S481 is second only to Intel's 3002; however, the strong I/O capability is more of a necessity in the TI

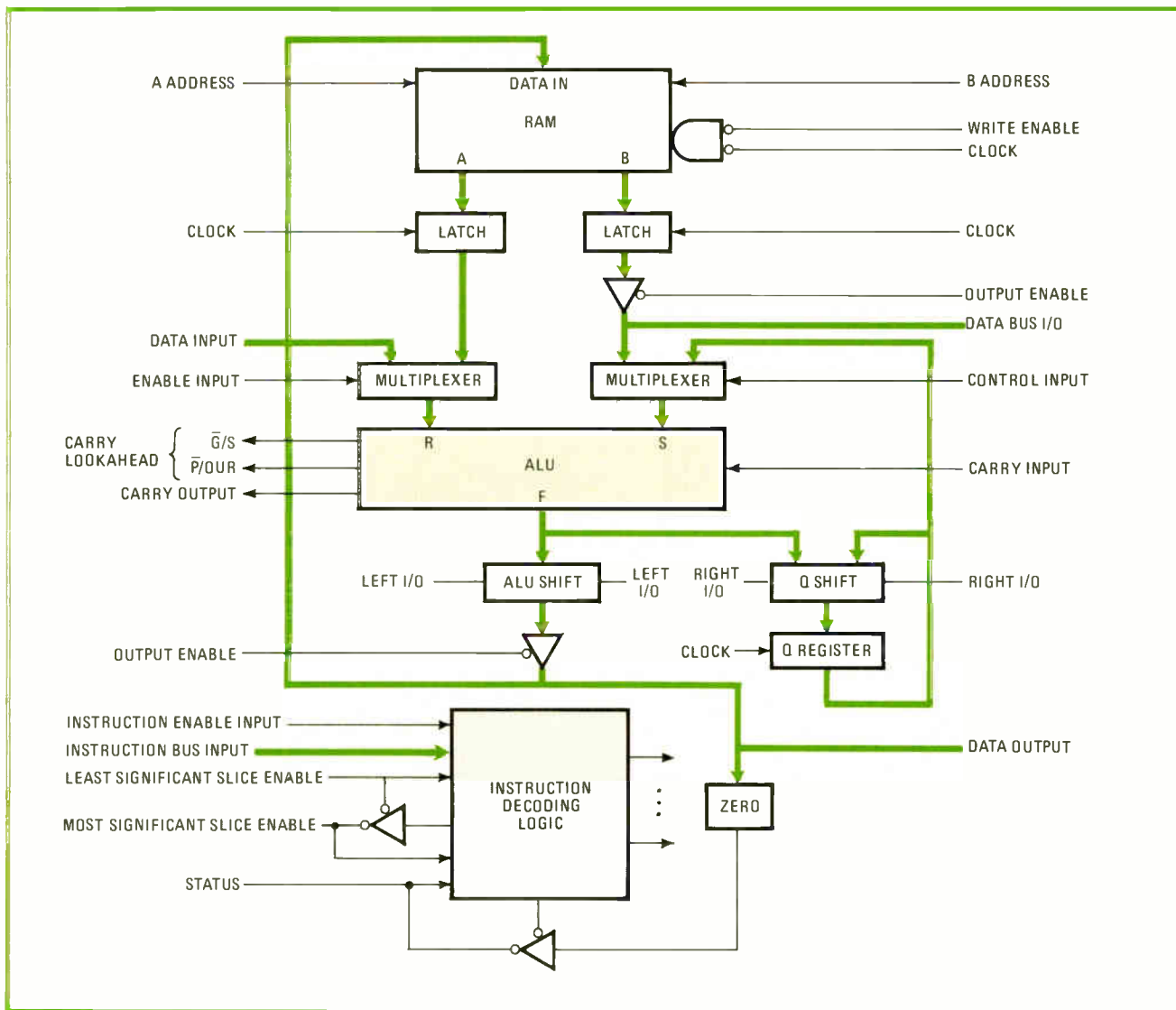

8. Refined. The Advanced Micro Devices Am2903 is a refinement of the Am2901. Normalization logic allows the mantissa and exponent of floating-point numbers to be adjusted simultaneously, and multiply and divide logic is also built in, making the 2903 a good number-cruncher.

device because it lacks an internal register file. TI's idea for the 74S481 is for it to be used in a memory-to-memory architecture similar in principle to that of its 990 minicomputer. Latches on both input ports make it easy to use any of several multiple-port RAMs in the TTL family for an external register file.

In addition to the accumulator and its extension, two other registers (which are actually counters) are provided for the express purpose of addressing memory. Either or both of these counters may be incremented while an operation is being performed in the ALU, making the 74S481 the only processor element to offer any form of multiple-ALU capability. Because of its arithmetic strength (it features preprogrammed multiply and divide), as well as the large corresponding number of instruction-control lines and its lack of an internal register file, the 74S481 is clearly optimized toward minicomputer and signal-processing applications.

A recently announced processor element is AMD's Am2903. As can be seen by comparing its diagram (Fig. 8) with that of the 2901 (Fig. 5), the 2903 is basically a

refined version of the earlier device. It contains the same internal register file, but is unique in its provision of hooks to expand the file externally if needed. In addition to built-in multiply and divide logic, the 2903 contains normalization logic that allows the mantissa and the exponent of a floating-point number to be adjusted simultaneously. Moreover, as in the 10800, parity is generated for the ALU output, to facilitate error detection and for generating cyclic-redundancy-checking codes.

The 2903 requires four more instruction lines than the 2901 and is housed in a 48-pin dual in-line package as against the 2901's 40-pin DIP. Although the 2903 has several additional basic arithmetic and logic instructions, the 2901 is probably preferable in most controllers and medium-speed minicomputer applications. But the 2903 is an excellent choice for number-crunching applications because of its added capabilities. AMD is in the unique position of having two processor elements in its bit-slice family, each optimized for different applications. □

Part 2 of this article on bit-slice processors will cover their microcontroller elements, related chips, and design support considerations. It will appear in *Electronics*'s next issue.